

Rec'd 1/9/82

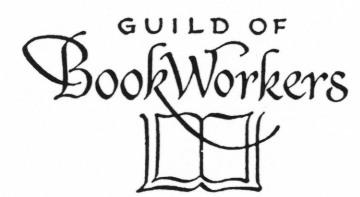

GUILD OF BOOK WORKERS JOURNAL

Volume XVII Numbers 1-2-3 1978-1979



GUILD OF BOOK WORKERS JOURNAL

Volume XVII Numbers 1, 2, 3

1978-1979

Combined Issue

Fall - Winter - Spring

Published three times a year by the Guild of Book Workers, Inc.

a not-for-profit corporation

663 Fifth Avenue, New York, N.Y. 10022

CONTENTS

The Bound Codex from its Origin to the Early Middle Ages / Berthe van Regemorter, translated by Mary E. Greenfield	1
Identifying Eighteenth Century American Bookbinders / Willman Spawn	25

PROGRAMS / Janet Saint Germain

A Visit to Philadelphia / Janet Saint Germain	38
A Visit to New York Central Supply Company / Janet Saint Germain	39
Behind the Scenes at Swann Galleries / Maggy Magerstadt Rosner	39
A Visit to the Bindery of Fritz and Trudi Eberhardt / Janet Saint Germain	41

ANNUAL REPORTS

President's Annual Report / Mary C. Schlosser	42
Minutes of the Annual Meeting / Grady E. Jensen	44
Treasurer's Report / Grady E. Jensen	46
Bylaws of the Guild of Book Workers / 1979 Revision	47
Goals and Future Planning / Sylvia Anderle and Judith Reed	51
Exhibition / Susanna Borghese	52
Library / Stanley E. Cushing	52
Membership / Jeanne Lewisohn	53
Program / Janet Saint Germain	53
Publications / Jerilyn G. Davis	54
Publicity / Caroline Schimmel	55
Supply / Mary E. Greenfield	55
Workshops / Nelly Balloffet	55
Report of Visit of <i>Chambre Syndicale Nationale de la Reliure- Brochure-Dorure</i> (Paris) to Guild of Book Workers (New York City) / Polly Lada-Mocarski	56

The Cover: Papyrus 337, a small book in codex format. See page 1.

Courtesy of the Beinecke Rare Book and Manuscript Library, Yale University, New Haven, Connecticut.

Editors for this issue: Susanna Borghese, Stanley E. Cushing, Jeanne Lewisohn, assisted by the Publications Committee.

THE BOUND CODEX FROM ITS ORIGIN TO
THE EARLY MIDDLE AGES / *Berthe van Regemorter*,
translated by Mary E. Greenfield

Berthe van Regemorter was born in Malines, Belgium, in 1879 and lived most of her life in nearby Antwerp. She studied bookbinding and gold tooling in Brussels and with Sangorski and Sutcliffe in London. A long career as a binder included over twenty years of teaching at the *Institut des métiers d'art* in Antwerp and at the *Ecole nationale d'architecture et des arts décoratifs* in Brussels. Her bindings were exhibited in Antwerp in 1923 and in Brussels in 1924.

Her studies of early binding structures seem to have started on her retirement, but in reality she had always been interested in the evolution of techniques and had realized their importance. When she was seventy-two, she was invited to teach the history of bookbinding at the *Institut du livre* of the Plantin-Moretus Museum. From then until her death in 1964, aged eighty-five, she traveled, visiting libraries and studying bindings wherever she went, and, in due course, publishing articles based on her observations.*

Since the time that Berthe van Regemorter wrote, the study of codicology - the archeology of the codex - has emerged as a science. Present students of early texts can often establish the number of papyrus rolls cut up to make up a codex or tell whether or not a parchment skin was folded to make up a gathering. Pricking, quire construction, methods of folding and dimensions are taking their place with paleographical and textual evidence in dating and placing early manuscripts. Although bindings are now being described in far more detail than formerly (whether decorated or not), analysis of the binding structure has not yet taken its place beside the study of the book block itself. This is understandable. Although the literature on the decoration of bindings is extensive, the literature on binding structure and technique is very small. Berthe van Regemorter was one of the pioneers in this field and certainly the most prolific of them, having published nineteen articles on binding. Scholars therefore turn to her, even raising her to their own level and speaking of "... the late Belgian scholar, Berthe van Regemorter." Her reputation was enormous and she saw books we will never see in their then state of preservation, if, indeed, we are ever allowed to examine them at all.

The interest of scholars in codicology is telling us a great deal about the construction of the book block, information not available when BvR was

Mary E. Greenfield is Head of the Yale Conservation Department, New Haven, Connecticut, and Supply Chairman of the Guild of Book Workers. The article here translated first appeared in *Le Moyen Age*, Vol. 61, 1955, and is published with their kind permission.

*This brief biography is taken from the obituary by Jean Irigoien which appeared in *Scriptorium*, 20:2, 1966.

writing. Recent discoveries have also added to our knowledge. So, although she made some observations with which we may now disagree, this does not detract from the value of her work as a beginning in codicological analysis which will, I hope, in the future include all aspects of the book.

THE BOUND CODEX FROM ITS ORIGIN TO THE EARLY MIDDLE AGES

The history of an artistic craft is usually studied in a fragmentary way; one becomes interested in a certain period — one evaluates the most beautiful examples of that period — but one doesn't bother to find out how the craft slowly evolved and why one finds identical characteristics very far from the place where one originally encountered them. Taking advantage of the examination of rare objects that I recently had the pleasure of seeing, I am going to follow the evolution of binding from its origin to the early Middle Ages.

The latest discoveries have shown that between the period of the *volumen* [roll] and the parchment codex, there was a period of transition when the *volumen* was not yet dethroned but was not the only book in favor. The first codices were made of papyrus and they were bound. It is Martial who tells us this when he ironically advises using a fir board so that the toga won't fray the papyrus:

*Ne toga barbatus faciat vel penula libros
Haec abies chartis tempora longa dabit.*

(Book XIV, Epigr. 84)

A leaf of papyrus in the British Museum comes from a little Latin codex of that period.¹

A craft doesn't evolve all at once. In general it is adapted from something that already exists. This was so with binding and it was diptychs and polyptychs which were to provide the material from which bindings were to evolve. The description published by Professor G. P. Cariatelli of a codex bound in wood discovered at Herculaneum is very interesting in this context.² They did not use metal rings; the leaves of this codex were united by means of a thread going through the wood; it was therefore *bound*. Let us note in passing that the wood was not fir but something much more precious: box. A little tablet of the Greco-Roman period in the Egyptian Museum in Cairo³ also

1. J. Mallon in *Emerita*, Vol. 17, 1949, pp.1-8.

2. *Pompeiana*, Naples, 1950, pp. 268-278.

3. B. van Regemorter. "La reliure des manuscrits grecs," *Scriptorium*, VIII, p. 17.

shows the use of thread to attach the two little boards; this thread goes through tunnels bored in the wood. These two objects may be considered as typical precursors of the bound codex (Fig.1).

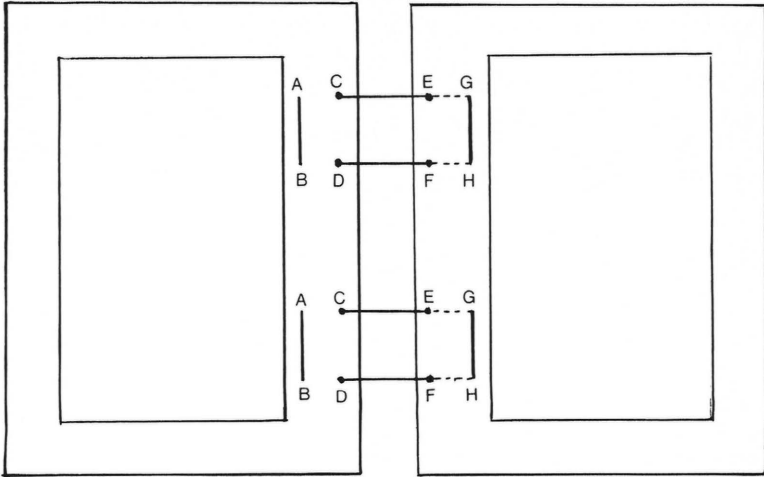

Fig. 1.

The slow evolution of the bound codex follows:

The papyrus text is preserved, in the beginning, by two little boards which resemble antique tablets. These little boards have, on the inside, a cavity for wax, but when they serve as a binding the cavity remains empty; leather thongs attach the text to the wooden boards.

The next step is the discovery of the half leather binding: the text is still pressed between two wooden boards, but the spine is covered with a scrap of leather slightly larger than the spine, the surplus being pasted to the wooden boards.

Next we see the role of the leather becoming more important and covering not only the spine but about one-third of the boards.

From the fourth century on there are full leather bindings; at first they were made without a wooden support, like portfolios, or with papyrus boards. The half leather binding was not abandoned and in the Chester Beatty Library in Dublin we can admire two half leather bindings with cedar boards, and one full leather binding with papyrus boards, all of which come from the same

find made in Egypt, and which date from the sixth century. The half leather bindings contain the finest manuscripts.

Before describing examples of these different types I must talk about the sewing; this is a very important point.

Sir F. G. Kenyon made a detailed study of the Greek Biblical manuscripts belonging to Sir Chester Beatty⁴ and he gives us the exact composition of these volumes. There are twelve of them, subdivided into three for the New Testament and nine for the Old Testament. They date from the second to the fourth centuries, the oldest being Volume VI (Numbers and Deuteronomy) which Sir F. G. Kenyon attributes to the first half of the second century. It would have been very interesting to have been able to establish the way they were sewn. Unhappily all these precious texts are badly damaged and have had to be put between glass as separate leaves. We can only be sure of the sewing of Volume I (The Gospels and Acts, dating from the first half of the third century). One page of the Gospel of Saint Luke has a hole left by the sewing, 7 mm from the fold, and on the other side of the fold we find a hole in the same place. A second hole seems to exist 7 cm lower, 9 mm from the fold. The fact that these holes are not *in* the fold, but *slightly in from it*, give evidence of a primitive stab sewing which must be similar to the sewing of the double leaves of Chinese and Japanese books. Volume I was made up of 110 folios; no other method of sewing was possible.

Volume II (Pauline Epistles) was a single gathering of ninety-two leaves. Volume VII (Isaiah) and Volume IX (Ezekiel and Esther) were also single gatherings.

Volume V (Genesis) was made up of gatherings of ten leaves and Volume XII (Enoch and some Homilies) of gatherings of twelve leaves.

Although all these manuscripts form part of a group, there is a gap of two centuries between the oldest (Volume VI, Numbers and Deuteronomy, first half of the second century) and the latest (Volume XI, Ecclesiastes, fourth century) and yet one sees no evolution in the composition of the gatherings, which results from no specific decision, but seems to be the result of chance and the possibilities of the materials at the disposition of the scribe.

Another group of manuscripts probably confirms this supposition. I am thinking of the Gnostic manuscripts of the fourth century, coming from Upper Egypt, which are in the Coptic Museum in Cairo, but which are not yet available to the public. They are all bound and some are single gatherings. Let us hope that it will soon be possible to study them and that they will not be put between glass before all the details of their technique have been exactly

4. *The Chester Beatty Biblical Papyri*, London, 1930.

recorded. Studying them should show us the way in which Sir Chester Beatty's manuscripts (the oldest Biblical manuscripts known) were put together.

Careful study of the wooden codex from Herculaneum as well as the tablet from the Egyptian Museum in Cairo (Fig. 1) shows that sewing with two separate threads, which we will study later, is a survival of the way in which boards were attached in the first centuries of our era. They did it with *two* ties.

The binding of a Gnostic manuscript in the Coptic Museum in Cairo substantiates this technique. This manuscript was made up of nineteen gatherings of papyrus folios⁵ and was probably held together by chain stitching. The binding, which is intact, although separated from the codex itself, has a band of leather protecting the spine and *two little leather thongs* go through this covering in four places (Fig.2). The upper thong goes through 1 and 2 and is knotted before being pasted to the outer leather; the lower thong

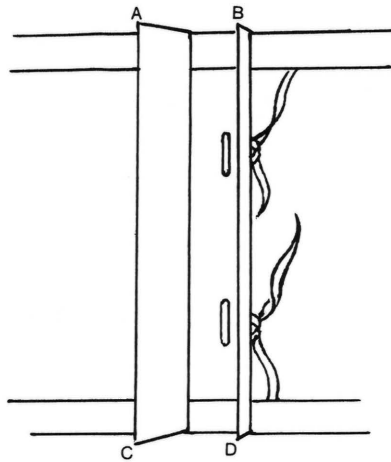

Fig. 2.

goes through 3 and 4 and is also knotted before being pasted. There was no connection between the two ties. This manuscript is attributed to the fourth century. The boards of Coptic Codex 3-3a in the Chester Beatty Library bear the traces of similar ties (Fig. 3). Each board has two little tunnels bored in the wood; they start in the middle of the edge of the board next to the spine and come out in the groove which is parallel to the spine; in putting the boards

5. *Vigiliae Christianae*, III, 1949, pp. 129-141; *Scriptorium*, VIII, 1954, pp. 17-18.

side by side one sees that although the holes in each of the boards are an equal distance from each other, they do not correspond. On the left hand board the upper hole is 14 mm from the head; on the right hand board the hole is 38 mm from the head; the lower hole is 35 mm from the tail on the left, 12 mm on the right. Two thongs go across the book block, attaching it to the binding. One went from the upper hole of the front board to the upper hole of the back board; the second bound the two lower holes; probably the ends of the ties were hidden between the gatherings of papyrus.

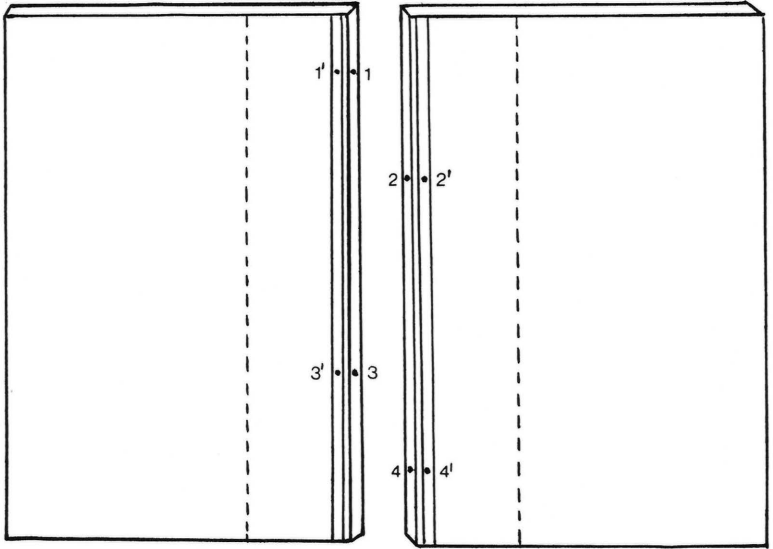

Fig. 3.

It is Coptic Codices A and B in the Chester Beatty Library, discovered in Egypt and both of parchment, intact, and attributed to the sixth century, that allow us to study early sewing.

C. T. Lamacraft who restored these volumes has described the technique.⁶ I do not agree with him when he says that the sewing was two-on; his drawing is quite clear and leaves no doubt. The volumes were sewn with *two separate threads*. The thread which sometimes went around the head of the gathering to lessen the strain on the spine is unimportant. What is significant in this

6. In *The Library*, Vol. 20, 1939-1940, pp. 214-233.

technique is that there was never any thread in the center of the gathering, proof of the use of two threads and two needles.

The fold in the middle of the gathering was pierced four times. The thread towards the head went through the gathering at 1; it lay in the center of the gathering and came out at 2; it went into the next gathering at 2, lay in the center of this gathering and came out at 1; it went into the third gathering at 1 and continued back and forth. Each time the thread went underneath the sewing of the previous gathering to make a type of knot. The thread near the tail did exactly the same thing, from 3 to 4 and from 4 to 3 and then again from 3 to 4 etc. There was never any thread between 2 and 3. *It is attachment with two thongs that has evolved into sewing with two independent threads.*

One often finds this sewing with two needles later on. First, not much later, but far from Egypt, in Northumbria in the seventh century. The famous manuscript of Saint Cuthbert, the Gospel of St. John which is now in the library of Stonyhurst College, is sewn with two separate threads. However, there is a slight difference between the binding of this book and that of the Coptic manuscripts; the end of the thread was first attached through the board at 1; the thread was also attached to the board at 2 after having gone from 1 to 2 inside the gathering. The rest of the work was identical with that of codices A and B of the Chester Beatty Library. At the last gathering the thread was attached to the back board as the thread of the first gathering had been to the front board. Nowhere is there any thread between 2 and 3.

The binder Roger Powell has given an excellent description of the binding of the manuscript of Saint Cuthbert.⁷ He has included a drawing explaining the sewing which he has allowed me to reproduce (Fig. 4), and for which I am sincerely grateful.

It is in Ethiopia that we still find this technique of sewing with two separate threads. The Ethiopian binder uses the technique of the manuscript of Saint Cuthbert, that is to say of thread attached to the board first. All the Ethiopian manuscripts, from the fifteenth through the nineteenth century that I have seen, are sewn this way. This technique is nothing but a perfection of what was done in Lower Egypt in the sixth century, and let us not forget that there was always a very close relationship between Ethiopia and Alexandria; actually, until 1950 the Bishop of the Ethiopian Church was always named by the Patriarch of Alexandria and this tradition goes back to the fourth century when Saint Athanasius named the first head of this church. It is probable that this bishop had Egyptian scribes and artisans at his disposition. The origin of the sewing of Ethiopian manuscripts is therefore easily understood, all the

7. *The Relics of Saint Cuthbert*, about to be published for the Friends of Durham Cathedral.

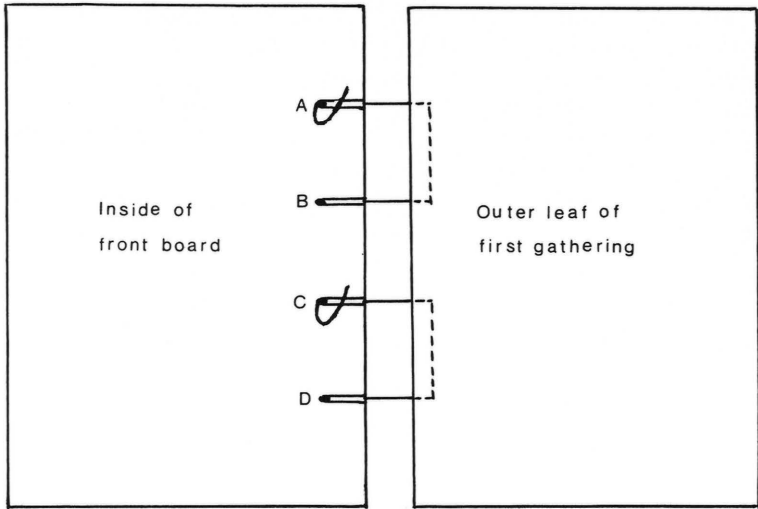

Fig. 4.

more so as Ethiopia is very much isolated so that the technique of Mohammedan books has had no influence.

If study of the sewing of the book of the Mediterranean basin is necessary in ascertaining its diffusion, it is equally interesting to see the evolution of binding in the West. For a long time no interest was taken in bindings of the early Middle Ages unless they were very sumptuous. Their study is limited to descriptions of carved ivory and the gold or silver plaques which ornamented the boards.

The more modest volumes, bound in leather and generally without ornamentation, have not been noticed. Their binding has been confused with that of volumes of the thirteenth or fourteenth centuries, even when the date they were written has been certainly determined; in this case they were thought to have been rebound a few centuries later.

Only the technique of bindings can tell us if Carolingian manuscripts are in their original bindings or not. We are going to see what the distinguishing signs of Carolingian binding are and this study will show us that in the very early Middle Ages the craft of the binder owed much to its Mediterranean origin.

Karl Christ⁸ has written about the plain Carolingian bindings from Reichenau, Fulda, St. Gall, and Freising; he describes a few tools used for this rough binding. As a result of this article, Heinz and Kattermann⁹ studied the technique of the bindings of Reichenau, but they describe them as if they were the only type of Carolingian binding. Since then I have investigated the traces of this technique and have found extremely interesting manuscripts relating to it in several French libraries.¹⁰

Now that we know the type of sewing used for the manuscript of Saint Cuthbert, it is easy to follow the evolution of binding in Carolingian times.

The Northumbrian binder attached his sewing thread to the front board; he finished by attaching it to the back board. We have seen that this method comes from Alexandria, either directly or via Rome, but in any case there is no possible doubt as Ethiopian sewing is proof of the diffusion of Coptic sewing.

In the eighth to the tenth centuries the bindings of Coptic manuscripts owed a large part of their solidity to the threads which joined the book block to the boards; as the boards were made of papyrus it was easy. Western manuscripts also had threads to solidify their binding, but these volumes are generally heavier and thicker than those of the Near East; it was necessary to find a technique better adapted to western materials. It wasn't easy. A manuscript in the Municipal Library of Autun (No. 19-18 S) is a striking example of the difficulty the binder encountered in resolving this problem (Plate I). The thread of the sewing is lodged several times in grooves bored in the wood and is held there by means of ties. As this system is very complicated, the binder realized that he had to simplify it.

Let us see how he went about it (Fig. 5).

A groove, deep enough to hold a cord, was bored in the outside of the board: A-B of the diagram. At the two ends, A and B, a hole through the wood was bored. On the inside of the board, two oblique, converging grooves which met at C were cut. These are the lines A-C and B-C. A tunnel large enough to hold two thicknesses of cord went from D in the middle of the edge of the board to C (on the inside of the board). The two boards were prepared in the same way, the only difference being that the groove from A to B was a little deeper in the back board than it was in the front.

The binder put the front board flat on his table or bench, laid the center of a fairly long cord in the groove A-B; threaded the two ends through the holes A and B, laid one of these ends in the groove A-C, the other in the groove B-C. He

8. In *Festschrift Georg. Leyh*, Leipzig, 1937.

9. *Archiv für Buchbinderei*, 1938, p. 33; 1939, pp. 17-31.

10. B. van Regemorter, "L'Evolution de la technique de la reliure du VIII^e au XII^e siècle," *Scriptorium*, II, pp. 275-285.

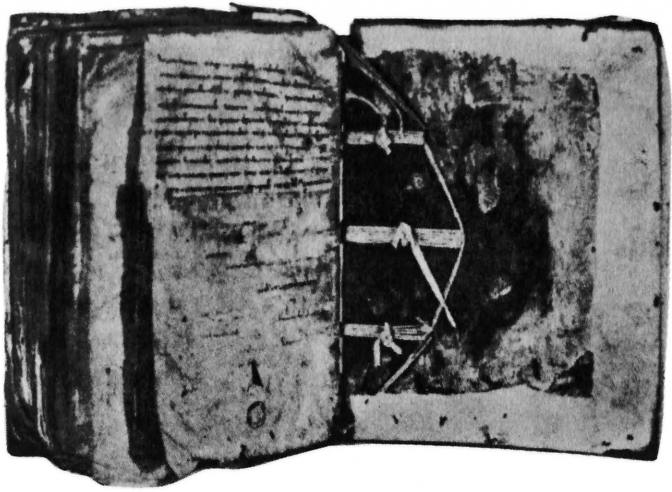

Plate I
Municipal Library of Autun, Ms. 19-18S

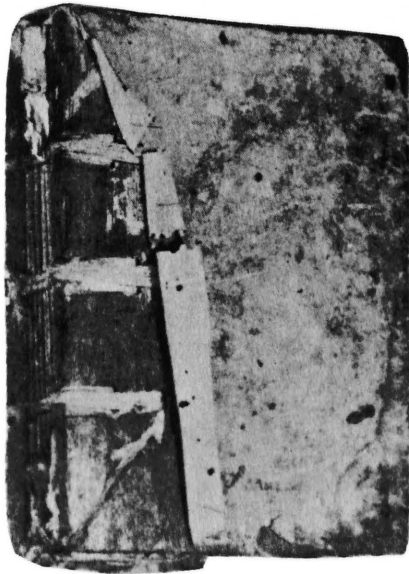

Plate Ia

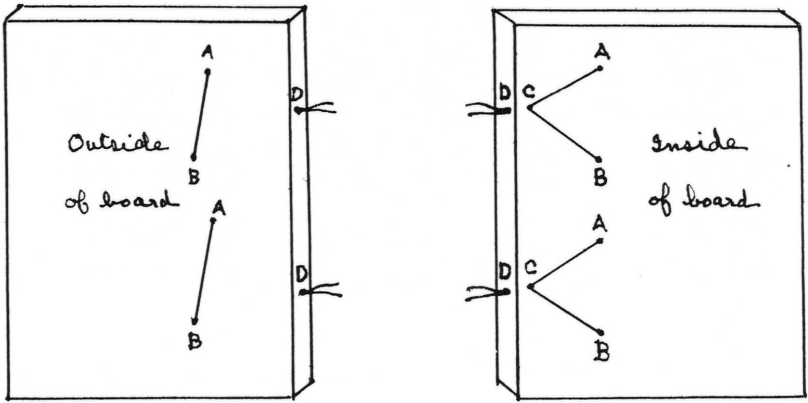

Fig. 5.

joined them and threaded them through the tunnel C-D. The threads were then stretched vertically from D to some temporary point of attachment.

It is on this base that he sewed his volume with a single thread. The sewing finished, he detached the cords and threaded them into the back board in exactly the same way that he had in the front board, with the difference that, to assure the strength of his binding, he wound the cords around each other before placing them in the groove A-B and it is for this reason that the grooves were slightly deeper on the back board.

It is the combination of two methods, "Coptic-Greco-Roman," which gave birth to Carolingian binding; the thread which is attached to the board and the cord which goes through it. This binding, although a little heavy, stood up well for several centuries, with a few variations. It wasn't until the eleventh or twelfth centuries that western technique definitely separated from that of the Near East.

It is in the eleventh-twelfth centuries that the *sewing frame was invented*. The sewing frame is, in a way, a miniature tapestry maker's frame on which the binder stretches his cords to facilitate sewing. It serves its purpose well and is still used, unchanged since its inception.¹¹

In the early Middle Ages they liked books with smooth spines; cords made unpleasant bumps; also the binder tried to conceal his way of working. He attached a strip of leather as wide as the spine to the volume. The strip was a little longer than the spine and projected beyond it in a half-moon shape. The leather of the binding itself rested on this strip and the spine seemed smooth

11. See Plate 19 of *Scriptorium*, II, reproducing a miniature of Ms. Patr. 5 of the Bamberg Library; it shows a monk sewing with a sewing frame. The ms. is from the XIIIth century.

because the binding wasn't glued to the spine. Only the turn-ins on the boards were pasted. The protective strip was attached to the volume with long stitches of thread which went inside the gatherings. It was attached to the leather of the binding by a kind of embroidery around the edges of the tabs. The half-moon which projects beyond the spine is thus made of two, or sometimes even three, thicknesses of leather. Often this tab was cut down later on. It is always interesting to examine this part of the binding if one thinks one is looking at an original binding: the longer the tab, the older the book, because this projecting half-moon diminished little by little before disappearing completely.

The edges of the boards next to the spine, particularly near the head and tail, are weak points from the point of view of the strength of the volume.

It is certainly for this reason that the Carolingian binder added the strip of leather. The Gnostic manuscript of the fourth century in regard to which I mentioned the existence of two ties which attached the gatherings of the text to the binding (Fig. 2) shows a detail of technique which had the same purpose: *a strip of leather which covers not only the back but part of the first and last leaves (A, B, C, D of the diagram)*. The strip of leather works very well. The bindings of Greek and Armenian manuscripts took up its use, replacing leather with cloth. Coptic binders from the eighth to the tenth centuries had already realized its worth. One also finds a trace of this technique in bindings of the early Middle Ages. Ms. No. 5413-5422 in the *Bibliothèque Royale* in Brussels and Ms. S 41-Libri 38 in the Municipal Library of Autun have a scrap of leather which covers part of the spine at the head and tail, and which extends over the two boards. The cores of the headbands go through the boards and the leather so that the leather is attached to the boards. It is the same technique as that which was transformed into the high headbands of Greek, Armenian, and Syriac manuscripts.

We have no knowledge of the earliest *headbands* although C. T. Lamacraft says that colored threads from the head and tail prove that codices A and B in the Chester Beatty Library had them. In his reconstruction of these bindings he has made a silk headband in two colors on a core of leather, but nothing proves that the originals were like this. Some eighth-tenth century Coptic manuscripts have headbands, others don't. When they have headbands they go along part of the board and are then attached through it, a technique similar to that of Greek and Armenian manuscripts.

The leather of the beautifully bound manuscript of Saint Cuthbert finishes off at the head and tail of the spine in a rather peculiar way: a white thread which goes into the center of each gathering also goes through the leather. A blue thread intermingles with the white thread but goes only through the leather; this forms a slight ornament at the head and tail where modern

headbands are found. On the outside we see two parallel lines of little stitches which do not meet, one white and one blue. One finds traces of two lines like this in the leather of the spine of the Cadmug Codex of Saint Boniface at Fulda. This is one of the reasons that I have said that that binding seems to have been bound in the same bindery as that which bound the manuscript of Saint Cuthbert.¹²

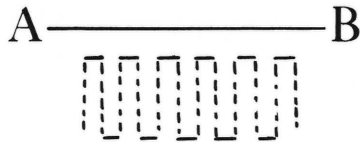

I have never found this technique anywhere else except in Ethiopia. All the Ethiopian bindings have two little horizontal lines at the head and tail, lines made of stitches that don't meet. Ethiopian headbands are a narrow plait of leather resting on the edge of the spine at head and tail; the stitches visible from the outside are those of the thread which goes through the gatherings and attaches the plait to the covering in a very ingenious way (Fig. 6). Like sewing with two threads, this ancient technique was used in Ethiopia until the nineteenth century. This shows where one should look for the origin of a detail of two bindings of the early Middle Ages.

Let us leave the purely technical aspect to consider how the earliest bindings looked. Again the Chester Beatty Library will be very useful to us.

Two sycamore boards bought in Cairo by Sir Chester Beatty about twenty years ago and cataloged as Coptic Codex No. 11 are a primitive binding. The text is gone but there can be no doubt on this subject.

They measure 9.6 cm in height; 8.6 cm in width; they are 1 cm thick. The outer side is ornamented with a carved decoration; the inside has a deep (5 mm) hollow with a border all around of 1.4 cm in width. It is the earliest type of binding: two tablets (diptych) whose hollows have never contained wax. That these two boards are not the boards of a tablet, but certainly those of a binding is proved by the fact that two holes have been bored in each board where the wood is thinnest, near the edge towards the spine, and an equal distance from head and tail. The holes are too far in from the edge to have been the place where metal rings could have gone through the wood, and besides the inner edge of the boards would have prevented the tablets from opening

12. *Scriptorium*, III, pp. 45-51.

and closing easily. There is only one possible explanation: the papyrus codex was probably made up of only a few gatherings. These were held together by a kind of chain stitching and the whole book was pressed between the boards and bound to them by little leather thongs which went through the wood.

The single board of the Coptic Codex No. 12 from the same library, also of carved wood with a hollow that never contained wax, has the same holes bored, coming out at the edge of the hollow; here we also find the end of a little leather thong. Coptic Codex No. 9 has, as well as the holes for the leather thongs attaching the text, a smaller hole near the corner of the board at the fore-edge. This hole is bored at 15 mm from the head and fore-edge of the board. What was it for? Martial gives the solution when he says "the fir board which keeps your toga from damaging the edges of your papyrus." One must not forget that the codex was often hung from the belt or the wrist; the hole at the fore-edge corner must have been for a strap from which the codex was suspended.

Coptic Codex No. 10, also consisting of two boards without text, is a little different and one already sees a slight evolution in technique. The method of attaching the boards to the papyrus book block is no longer the same. There is still a hollow inside the board, reminiscent of the wax tablet, but the holes bored in the boards are in different places. There are five on the edge of each board at about equal distance from each other; those at head and tail are slanted and very near the edge. It is evident that these little holes do not go through the wood. They are only 1 cm deep. The binder probably attached the boards to the codex by threading thongs or thin strings in these holes and gluing them. The two holes at head and tail being slanted makes me think that sewing going inside the gatherings and wound around a thin strip of leather made a sort of headband whose ends were attached in the wood in these slanting holes.

Codex No. 9 is interesting from other points of view; the design on the outside, quite roughly carved, is typically Egyptian; straight lines divide the surface into squares in which there are triple concentric circles. One of these divisions has no circles; a scrap of papyrus with a Greek text was glued in it on each board. Unhappily this text does not give us any precise information on the provenance or date of the codex.

The edge of the board at the spine is square. The three other sides are rounded and very delicately carved on the edge to resemble serrated leather. Coptic leather bookbindings, much later (eighth-tenth centuries), have the covering of the edges cut in exactly the same way as the carving in these wooden boards, and the leather bookmarks of codices A and B in the Chester Beatty Library (sixth century) also have serrated edges; so this was a way of finishing leather that wasn't turned in, peculiar to Egypt.

Let us now examine two bindings from a period when the craft had made some progress. The hollow inside had disappeared; it is no longer a question of a *tablet adapted* to binding, it is a *binding* and the inside of the board is flat. The three outer edges of the boards are slightly rounded, the edge at the spine is square. Something new, a groove, parallel to the spine, is about 5 mm wide and about 5 mm from the edge. It is not very deep. There is no doubt about its usefulness. The binder covered the spine of the book with a band of leather a little wider than the thickness of the spine and the surplus was pasted to the board on each side. The edge of the leather was set in the groove which gave added strength. It was the primitive type of the half binding.

Coptic Codex No. 1 (Plate II) and Coptic Codex No. 2 in the Chester Beatty Library are bound in this way. They were discovered at the same time as the Biblical Greek manuscripts of which I have already spoken. One can therefore assume that they were of the same period which places them in about the third century, more or less. Of Coptic Codex No. 1 only one board remains (22.8 cm x 13 cm). To judge from the inlaid ivory with which it is ornamented it must have been a fine binding. A rectangular panel, 14.2 cm x 8 cm, formed the center of the decoration. It was surrounded by a little frame, 6 mm wide, representing a garland of laurel. A wider horizontal band (13 mm), parallel to the edge, emphasizes the head and tail. This band was also decorated with laurel leaves. Unhappily the central panel has disappeared; its little frame still has almost all the ivory of a vertical side and a third of a horizontal side. The two larger bands are intact. One can tell, thanks to the vertical side of the frame, that the carving was done specially for this binding. The laurel leaves are joined in the middle by a knot and point up and down in exact proportion with the central panel. When this binding was complete, having doubtless a handsome carved panel in the middle, it was surely a beautiful object in classical style. It was perhaps one of those bindings which provoked Saint Jerome's disapprobation.¹³

Coptic Codex No. 2 is of exactly the same type: groove to facilitate the pasting of the leather, inside of the board without a hollow, decoration of inlaid ivory, in this case almost intact but less important and beautiful than that of Coptic Codex No. 1.

Let us now study Coptic Codex No. 3, the technique of which we have already examined. Its decoration is most interesting. Here is a description of these two boards without codex: flat inside which still has traces of pasted

13. S. Jerome, ed. Hilberg, *C.S.E.L.*, V. LIV, *epist.* XXII, p. 193. Epistle to Eustasius: "They color parchment purple, they trace letters with liquid gold, they dress books with jewels, but naked, before their doors, Christ is dying."

leather (so there must have been an inner covering of leather); groove in the wood; band of leather pasted on a part of the outside of the board and fitting into the groove. This leather is naturally the prolongation of that which covered the spine, and about one-third of the board is thus covered. Two little tunnels are bored in each board; they start in the middle of the edge of the board next to the spine and come out in the groove parallel to the spine.

I have already drawn attention to the fact that the place where the holes are bored in the boards of this binding indicate a very early type, that of two thongs holding the book block and binding together. The decoration consists of very finely cut leather on a *gilded background*; some parts of the gilding have survived and are still brilliant. The design is geometric with a pretty clover leaf motif in the middle. Was the gilding done with a brush or with gold leaf? I would choose the latter hypothesis (Plate III). The manuscript was small; the boards are only 12.9 cm x 8.4 cm.

The art of cut leather which reached such heights in Persia in the fifteenth century is generally considered as an essentially Mohammedan art, and those who have studied it cite as the oldest example the binding on one of the Manichean manuscripts discovered at Turfan, now in the Berlin Museum.¹⁴ Juxtapose the design of the Turkestan binding with Coptic Codex No. 3 of the Chester Beatty Library, and one sees that they are of identical workmanship. The inspiration of the design is the same and the technique of each is equally skillful. Examples of cut leather on colored or gold backgrounds are excessively rare before modern times (I am speaking of the expert cut leather work of the Persian artists); aside from the two examples I have mentioned, only the Coptic bindings of the eighth-tenth centuries and the binding of the famous manuscript No. 1 of Saint Boniface at Fulda which also has cut leather on a gilded background, are known.

Recent Manichean studies have shown much interest in the manuscripts discovered in 1931 at Medinet Madi in the Fayum. They are written in Subachmimic Coptic and are one of the proofs of the rapid and considerable spread of Manicheism toward the west, as the manuscripts of Turfan prove its expansion to the east. In studying the technique of the binding we find proof of the early date of Codex No. 3 of the Chester Beatty Library which preceded the Turfan binding. Under these conditions it is very tempting to say that the art of cut leather is an Egyptian art which was introduced into Persia by Manichean zealots. It is almost impossible to suppose that, having come from Persia with the religion of Manes, it would have taken such root in Egypt that several centuries later it would still have been practiced by the Copts, and that

14. Arthur-U. Pope and Phyllis Ackerman, *A Survey of Persian Art*, pl. 951 B.

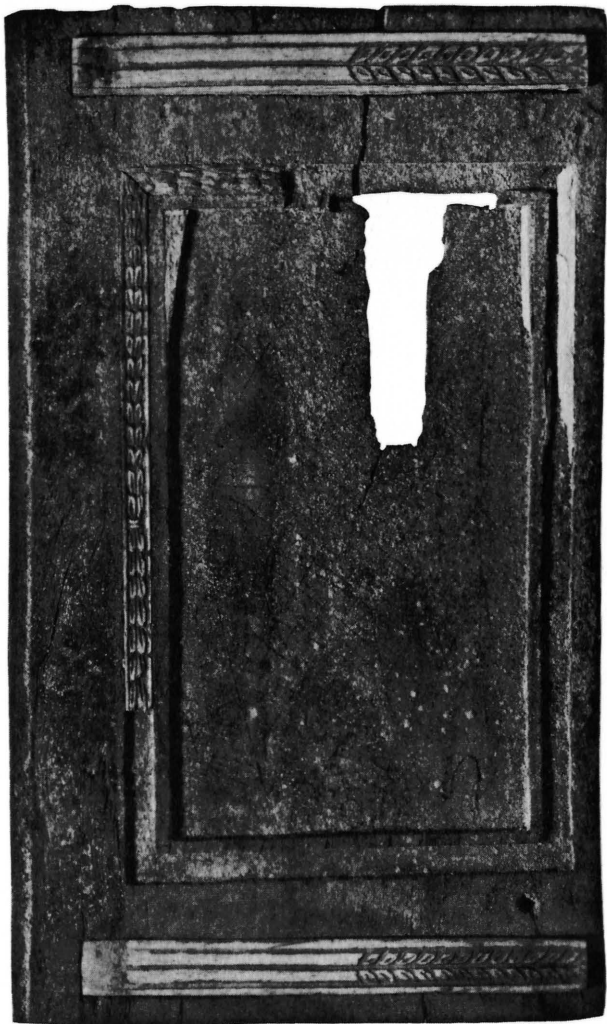

Plate II

Chester Beatty Library, Coptic Codex No. 1



Plate III

Chester Beatty Library, Coptic Codex 3-3a.



Plate III

the Egyptian Christians on the other hand would have assimilated this technique so well that they would have introduced it to the European continent in the eighth century. If one could prove that cut leather work is really of Persian origin, one would be justified in thinking that the book which interests us is an Egyptian Manichean manuscript.

To finish the description of a few examples of very early bindings, I will mention Codices A and B in the Chester Beatty Library of which I have already described the sewing. The purpose of binding being to preserve the text, one may say that the craftsman who bound these books created a perfect type. In spite of their age and the fact that they were hidden for centuries, these parchment volumes are intact. The leaves have not moved, the text is as clean as if it had just been written. This is probably because a wide band of leather attached to the head of the wooden board was wrapped twice around the book. At the end was a rectangle of bone which served as a slip to hold the band in place. A second wide leather band attached to the board at the fore-edge was also wrapped twice around the volume and held it closed cross-wise. This band was also held in place with a bone rectangle. The volumes were thus held as if they were in a press. Codex A contains the Pauline Epistles; Codex B, Acts and the Gospel According to Saint John. One feels that no trouble was spared to make handsome volumes: the quality of the vellum, the choice of cedar for the boards and of morocco to cover the spine and make the bands wrapped around the volume. The way in which the boards were attached to the book block is absolutely remarkable; a narrow hinge of leather of which one side was pasted to the book, was cut all along the other side into more than thirty little tongues; little ducts corresponding to these tongues were bored in the wood and the tongues were threaded into and pasted in these ducts. Only cedar could sustain such delicate work.

The edges were decorated with ink. There is a design representing a vase, similar to the only design in the text.

The leather spine is also surprising and admirable. The decoration is made up of horizontal tooled lines alternating with bands of animals and stylized flowers done with small tools.

A bookmark made of a rectangle of leather, also tooled with lines and small tools, was attached by a thong in the upper right hand corner of the front board. This leather has serrated edges. The little tools used on the spine and the bookmark show that this type of decoration of leather, which we thought was peculiar to our monastic bindings, was already in use in Egypt in the sixth century. The design of these tools also merits our attention. One finds almost identical ones among the tools used on Greek and Romanesque bindings. If some of the latter are particularly striking because of the truly architectural composition of their decoration, and because of their characteristic tools

representing Biblical characters, there are also more simple elements: stylized flowers, animals, birds, small strap work. This type of tool had already been used in Egypt on Codices A and B and on some eighth century Coptic manuscripts.

W. H. Weale, who was the first to discuss Romanesque bindings, thought that they were the work of the Benedictine abbeys of Northumbria. Since then the list of this type of binding has grown; an odd thing is that there are none in Italy. They are mainly in England and France. This fact, added to what we already know of the technique of binding, confirms the opinion that in the eighth and ninth centuries Oriental influences left traces of the craft of the binder in France and Northumbria.

Last I will speak of the *decoration* of the front board of the manuscript of Saint Cuthbert. In the article I wrote on the subject I said that the technique of the well-executed raised design was unknown to me.¹⁵ Since then Roger Powell has seen details that escaped me in my first visit to Stonyhurst College. A second visit, made recently, has convinced me that the raised design is on a base of strings pasted on the boards. The ends of the strings were taken through the board and disappeared on the inside of it. Georges Marçais and Louis Poinssot, who have published a detailed description of the bindings discovered at Tunis,¹⁶ speak of, among others, thirteenth century bindings which are decorated with raised leather on a base of strings. They think that this technique is exclusively from Kairouan; in fact, it was already being used in the eighth century in Northumbria. The origin of this type of decoration is, however, Mediterranean as is proved by a volume in the Chester Beatty Library. This is Syriac Ms. No. 2, dating probably from the eighth or ninth century, which still retains its original binding. Its only ornament is a swastika in relief on the leather. The technique is that of a base of strings pasted on the board, with the ends going through the wood and disappearing on the inside. The manuscript of Saint Cuthbert therefore has considerable importance in research on the diffusion of culture and crafts in the early Middle Ages; this venerable document of the seventh century shows its Mediterranean origin by three different details: sewing with two needles, the headband, the decoration.

Let the historian who has not specialized in the study of the book forgive me if I have spent too long a time on questions of technique; it is essential in tracing the influences and range of a civilization. A pleasing design is easily copied, but a technique is taught. My aim has been double: first to show that we now know exactly how the bound codex evolved from the beginning of the

15. *Scriptorium*, III, p. 47.

16. Georges Marçais and Louis Poinssot, *Objets Kairouanais. IX^e-XIII^e siècle. Reliures, verreries, cuivres et bronze, bijoux*. Tunis, Paris, 1948-1952.

Christian era, and second to emphasize that the techniques used in our *scriptoria* before the twelfth century come from the Mediterranean basin, either directly or indirectly.

NOTES BY MARY E. GREENFIELD

Diagrams

BvR was very casual about her diagrams. For instance, in Fig. 2 she left out the numbers and in speaking of Fig. 4 says 1, 2, 3, 4 when she means A, B, C, D. They have not been changed as they are perfectly clear.

Pages 2, 3

In 1973 wooden tablets with holes placed so as to hold them together accordion fashion, were found near The Wall in Britain. It has been suggested that they are another possible link in the transition from roll to codex. (Bowman, Alan K., "Roman Military Records from Vindolanda," *Brittania*, 5, 1974, pp. 360-373, Plate XLIV.)

Page 2.

J. Mallon dates this fragment before the beginning of the second century on paleographical grounds and after 80 A.D., as Martial, writing of the parchment codex at that time, speaks of it as new.

Cariatelli's diagram of the codex from Herculaneum:

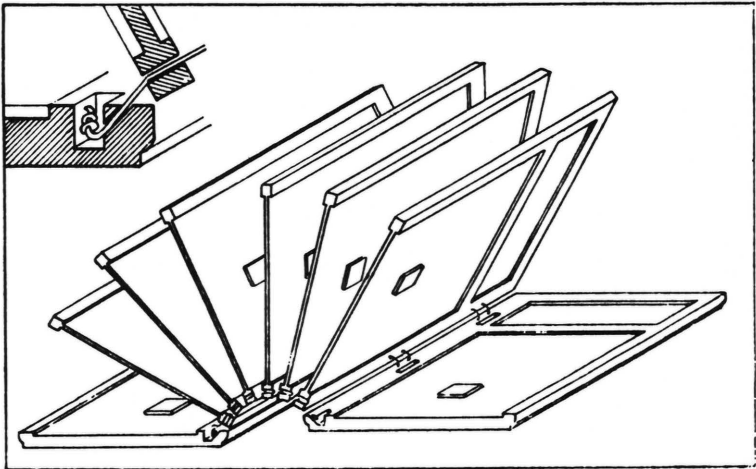

Page 3.

In "La reliure des manuscrits grecs," BvR describes this tablet in more detail. "The outside of the tablet . . . has a design drawn in the wood at the fore-edge. It is a little square poised on a corner with concave lines. It probably outlines the spot destined for the seal which closed it." The tablet must also have had an encircling thong as otherwise the boards would have opened to the width of CE and DF at the sewing edge.

Page 5.

The study of the bindings of early codices presents difficulties other than scarcity. First, if the book block is of papyrus it is usually very fragile and must be put between glass as soon as possible in order to preserve the text. In the past, few, if any, records of the attachment of the book block to the binding were kept. Second, the waste papyrus pasted together to stiffen the cover (cartonnage) often contains valuable information and so is often removed and taken apart so that it can be read. Douglas Cockerell speaks, somewhat acidly, of " . . . a number of leather sides from which the papyrus boards have been removed, either by insects or Coptic scholars." (*The Library*, 4th Series, 13:1, 1932, p. 5.) The binder must therefore depend on the scholars' findings as to quire construction, attachment, and dating — which seems to vary with the years and the scholars.

In the first excitement over its acquisition the Nag Hammadi binding was said to have nineteen gatherings. BvR naturally based her assumptions on this statement. The book has since been found to have only one. This makes Fig. 2 understandable, although it is still somewhat confusing as it is an attempt to show both sides of the spine lining at once. I hope that the following will make the construction clear:

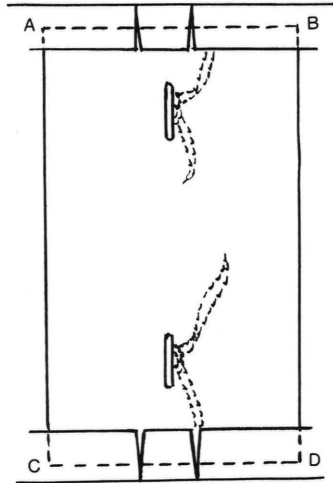

The sewing thongs went from the center of the quire, through the leather spine lining, and tied on the outside of it. The spine lining was then pasted to the outer cover which had been lined with sheets of waste papyrus. More waste papyrus was added over the spine lining and the turn-ins were folded over and pasted on top of it. Blank papyrus pastedowns, probably separate from the book block, were pasted over all. (Both drawing and description are based on information given by James M. Robinson in *The Facsimile Edition of the Nag Hammadi Codices, Codex III*, Leiden, E. J. Brill, 1976, Introduction, pp. xi and xiii, Plates 1-4.)

Page 5 & Fig. 3.

Roger Powell who examined the Chester Beatty bindings in 1953, and again in company with Peter Waters in 1960, has suggested a sewing similar to that of the Stonyhurst Gospel for this binding, as one that makes practical sense.

"In this instance, 3-3a, which may have been an early essay, the two threads would have been attached one to each of the holes in one board, and passed within the folds and from one quire to the next, of a codex made up (on this occasion) of an uneven number of quires:

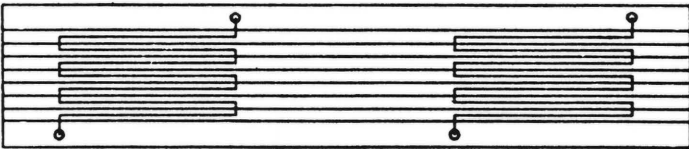

For the sake of clarity, kettle-stitches which might have linked quire to quire have been omitted from the diagram." ("Some Early Bindings from Egypt in the Chester Beatty Library: Additional Notes," *The Library*, 5th Series, 18, 1963, p. 223.)

Page 6.

I think BvR misunderstood Mr. Lamacraft's statement in the article she mentions. He said:

"In MS. 'A' the first, second, and last two sections were sewn 'all along' with double thread, leaving three loops in the middle of each (Fig. 2.) At each exit of the needle a looped or chain stitch was made round the thread of the previous section, thus tying them together in four places across the back. The remaining sections were sewn with two distinct sewings with single thread, leaving loops at the top and bottom of the middle of each section. In a few instances 'two sheets on' were sewn, the thread being passed over the head or tail of the section instead of making the loop in the centre of the fold, thus reducing slightly the thickness of the back caused by the thread."

Page 7.

Battiscombe, C. F. ed. *The Relics of Saint Cuthbert; studies by various authors, collected and edited with an historical introduction*. Oxford: printed for the Dean and Chapter of Durham Cathedral at the University Press, 1956.

Page 12.

Coarse cloth was used as a spine lining as early as the sixth or seventh century in a codex from Egypt. (Kasser, Rodolphe, pub. *Papyrus Bodmer XVII, Actes des Apôtres, Epîtres de Jacques, Pierre, Jean et Jude*. Cologny-Genève, Bibliotheca Bodmeriana, 1961.)

Pages 13-21.

Roger Powell, in the article mentioned above, has commented on all of these bindings. His observations and comments often differ considerably from BvR's.

Page 16.

Although the Turfan "binding" is interesting, it is somewhat disappointing. It consists of a small (9 x 11 cm) piece of cut leather work.

IDENTIFYING EIGHTEENTH CENTURY AMERICAN BOOKBINDERS / Willman Spawn

For thirty-one years I have worked for the Library of the American Philosophical Society, which is strong in eighteenth century imprints, many of them still in their original bindings. It was here that my interest was aroused to identify the early binder of many of the first books belonging to the Library. A great many of these books were not American but European imprints, gifts to the Society from members and other learned societies - yet they all looked similar to one another and to the American imprints of the same period: plain sheep bindings with red morocco labels decorated with a single roll in gilt. Only occasionally was there any other decoration. It seemed likely to me that all these bindings, so similar in appearance, style, and workmanship, were the work of a single Philadelphia binder, who bound or rebound them to order after their acquisition by the Library.

It had always been my practice as a restorer to make rubbings of every book before I repaired it, as a record of its original appearance, but there were many, many books in the Library that I had not had occasion to handle. It was not until 1955/1956, when I supervised the oiling of all the leather-bound books in the Library, that I had the opportunity to make rubbings of them and so compile a complete record of the Library's leather bindings. Naturally, I had hoped to find some clue to the binder of the similar bindings, such as a binder's ticket or even a signature. To my great disappointment, I found only

Willman Spawn is the Conservator at The American Philosophical Society, Philadelphia, Pennsylvania. This article is based on a talk delivered to the Guild of Book Workers on September 23, 1978.

three binder's tickets in American imprints and perhaps another half-dozen in European imprints. None of them were in any of the bindings whose binder I had hoped to identify.

In the spring of 1957 I decided to extend my research to another Philadelphia institution rich in eighteenth century imprints. I approached the Library Company of Philadelphia for permission to make rubbings of all its eighteenth century leather-bound American imprints. The Librarian, Edwin Wolf, gave the permission willingly - along with a warning that the project would take months, if not years. It did indeed take months, but the investment of time and energy was well worth it. Mr. Wolf also gave me some valuable suggestions: to study the Library Company's minutes for binding orders; to examine the Isaac Norris cash book for records of binding done for this merchant collector; and to use Robert Aitken's Waste-book¹ to identify his bindings.

I began on both aspects of the project immediately, and almost at once was rewarded beyond my expectations. Making rubbings in the Library Company's Americana collection, I found copies of titles I knew from the APS Library in exactly the same style of binding, which reinforced my belief that certain bindings had to be American, even local, and not European. And my first examination of the Aitken Waste-book showed me dozens of entries for binding various titles which I recognized from the shelves of the two collections. In fact, the very first entry I recognized solved a long-standing question. The Free Library of Philadelphia owns a copy of Hugh Blair's *Lectures in Rhetoric and Belles Lettres*, printed in Philadelphia by Robert Aitken in 1784, with an inscription from Gerardus Clarkson of Philadelphia to his son George dated 1788. The binding is magnificent red morocco, very elaborately gilt in Chinese Chippendale style. Despite the Philadelphia imprint, and the inscription, a binding of such quality and opulence seemed hardly to be American. I confess I shared this opinion, yet there in the Aitken Waste-book was the actual entry for binding the Blair for Gerardus Clarkson. I could now call it an American binding beyond any doubt, and the work of a known craftsman.

I felt I was now on the right track to the identification of a great deal of Aitken's binding, despite the lack of a ticket or signature in any of the volumes I had examined so far. Previous studies of American binding had relied a great deal on ticketed or signed bindings, but I could now go beyond this. The

1. "Waste-book . . . a rough account-book (now little used in ordinary business) in which entries are made of all transactions (purchases, sales, receipts, payments, etc.) at the time of their occurrence, to be 'posted' afterwards into a more formal book. . . in simpler forms of bookkeeping the Daybook and Journal were not distinguished from the Waste-book" — O.E.D.

Waste-book contained a number of entries for binding done for the American Philosophical Society and the Library Company. Using the binder's own records and my collection of some 2,000 rubbings of APS and Library Company books, I could single out Aitken's work from all the rest.

This method sounds straight-forward and promising of quick results, but in fact it involved hours of making rubbings, comparing them to the Waste-book and to each other, indexing the Waste-book customers and the Aitken imprints in Evans before I began to see real results. The customer index compiled by my wife proved invaluable in the end, for hundreds of books bound for these customers eventually ended up in the collections of the APS, the Library Company, and other libraries I have examined. Many times, a book which I assumed to be bound by Aitken, yet which could not be found in the Library's account, turned out to be a donation by one of Aitken's customers.

For example, I was intrigued by this passage from the diary of Manasseh Cutler, describing a visit to the library of Benjamin Franklin:

It was a single volume, but so large that it was with great difficulty that the Doctor was able to raise it from a low shelf and lift it on to the table; but with that senile ambition common to old people, he insisted on doing it himself, and would permit no person to assist him, merely to show us how much strength he had remaining. It contained the whole of Linnaeus *Systima Vegetabilia*, with large cuts of every plant, and colored from nature. It was a feast to me, and the Doctor seemed to enjoy it as well as myself.

The Franklin collection at the APS does not include a Linnaeus, but it does include a Miller's *Garden Dictionary* organized according to the Linnaean system and of the size so colorfully described by Cutler. It also looked like an Aitken binding. Referring to the Franklin card in the customer index, I located the actual entry for the binding of the Miller for Dr. Franklin, on August 8, 1786.

From the beginning I was fortunate enough to make identifications of this sort fairly often, and after a while they began to come in groups. I really had no chance to get bogged down from lack of results. There was no need to worry about lack of material; the Waste-book was filled with possibilities. To give you a sampling of the Aitken shop's production, in 1774 the shop produced 2,680 plain bindings, 192 gilt bindings, and 38 ledgers; in 1782 the shop produced 488 plain bindings (of which 242 were copies of the Aitken *Bible* just published), 43 gilt bindings, and 10 ledgers; and in 1798, near the end of Aitken's life, the shop produced 948 plain bindings, 62 gilt bindings, and 9 ledgers. (As an aside, it is interesting to note that in each of these years, the production of plain bindings accounts for 90 percent of the total.) After several years I had identified 1,266 Aitken bindings.

Once the Aitken tools were established and his bindings could be identified beyond doubt, it seemed possible to use the same technique in identification of his contemporaries and predecessors. Aitken was an outstanding figure in the eighteenth century Philadelphia book trade, but he was only one of some 150 binders who were active in Philadelphia in that century. Surely there were other binders who had been equally productive, if not as prominent or skillful. Using my thousands of rubbings - I now had at least 5,000 - and drawing on the wealth of eighteenth century documents still available in Philadelphia, I felt sure I could identify some of Aitken's peers.

As a beginning I had the names of the men employed by Aitken and recorded in the Waste-book. For example, the Waste-book contains entries for wages paid to James Leishman as a journeyman binder during the 1770s, and later for his purchase of leather and books in sheets, when he left the Aitken shop to set up for himself in Burlington, New Jersey, and afterwards in Trenton. Most of Leishman's proven binding is understandably very like that of Aitken. Leishman used his tools in almost the Aitken manner, to create a wide decorative border on the sides; his gilt spines are quite similar, also, with the design repeated in the first, third and sixth panels. However, where Aitken could vary the appearance of his bindings by choosing from his large stock of 42 decorative rolls, Leishman used the same three rolls and stamps on *every* binding - whether from lack of an assortment of tools or from lack of imagination I am not able to say. As a result, the most distinctive feature of Leishman's work is the exact similarity of his bindings and the monotony of the decoration.

By the time some of Aitken's contemporaries had been identified, I had examined sources of information for other Philadelphia binders in city and state archives, the account books of Franklin, William Bradford the second, Hall and Sellers, Mathew Carey, Drs. Thomas and Phinneas Bond, Dr. Benjamin Rush, in the archives of Pennsylvania Hospital, the Carpenters Company of Philadelphia, the minutes of the Library Company, the Philadelphia Contributionship for the Insurance of Houses from Loss by Fire, the Insurance Company of North America, the Bank of North America, the Religious Society of Friends, Christ Church, and in the personal papers of such merchants and collectors as Isaac Norris first and second, James Logan, and Stephen Girard. They were not my only sources - I have examined many more in Philadelphia and outside it - but I mention these particularly because each source contributed an exact identification for at least one or more binders of the 150 whose work I hoped to identify. It is certainly fortunate for my study that I have not had to rely solely on binder's tickets, for I now estimate that in Philadelphia, at any rate, they were used only by a dozen binders, and most of

these were stationers in business near the end of the eighteenth century.

Let me use the binders employed by Benjamin Franklin to illustrate my research methods. The Franklin account books in the APS Library list eight binders paid for work between 1730 and 1748. Unfortunately, the Franklin entries are brief and unrevealing; too often, when an entry gives the title of the book to be bound, it omits the name of the binder - and vice versa. Even so, only two of the eight binders, a John Hyndshaw and a Mr. Hill, remain to be identified. The six whose work I can now prove are William Davies, Joseph Goodwin, Nathaniel Holland, Stephen Potts, Johan Balthazar Schuppius, all from Philadelphia, and Charles Harrison of Boston.

The identification of William Davies' work was perhaps the easiest of all. The 1727 edition of Ellis Pugh's *Salutation to the Britains*, known in multiple copies all in the same binding, carries Davies' name in imprint on the title-page. His work is further documented by entries in the Quaker archives for pamphlets supplied to Friends in the Philadelphia area. The Quaker archives are a fruitful source of information on the eighteenth century Philadelphia book trade, for a Quaker printer or binder had to clear a publication with the Quaker overseers before he could proceed.

William Muir's name I first learned from Hannah French's *Hand Bookbinding in Colonial America*; my second reference was a note in the Treasurer's Book of the St. Andrew's Society of Philadelphia - "Paid William Muir 2 pounds for this book, 1757." This gave me an example of his binding, one of his decorative rolls, and a corner tool, but little else to go on. The archives of Pennsylvania Hospital added a little bit of evidence, the account book of Doctor Thomas and Doctor Phineas Bond supplied more, and there were the entries in the Franklin account books. In 1759 the *Pennsylvania Gazette* reported that Muir was the administrator of the estate of James Turner, an engraver. Eventually, in the city archives, I found William Muir's will, dated 1761, and a detailed inventory of his estate. The total value of the estate exceeded 1,000 pounds - perhaps the largest estate for a practicing binder and bookseller in Philadelphia. However, the inventory's importance lies not in its monetary value but in the detailed picture of the shop's equipment and supplies. Rolls, handstamps, three plows, and four sewing benches, fifty pounds worth of leather (English, Scotch, and Philadelphia calf skins, the latter designated as "ordinary"), plus a large quantity of pieces in the garret. The whole inventory takes up twenty-three folio pages, three pages of tools, even to the number of needles he owned - both sharp and dull.

In contrast to Davies and Muir, the identification of the work of Stephen Potts was long and complicated. Potts was a well-known and active binder from 1730 to his death in 1758, and friend of Franklin from his early days.

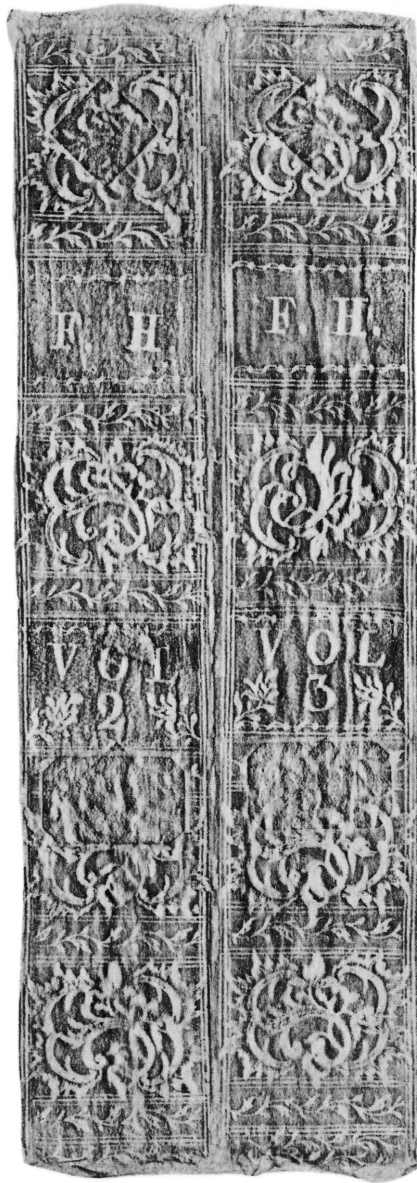

Bound by Robert Aitken.
Manuscript Writings of Francis Hopkinson, 5 vols.
Collection American Philosophical Society.

Surely he would have done binding for Franklin, and so he did - the account books substantiate that. But proving just *what* he bound was not easy to do.

To begin with, during the earliest period of the Franklin shop, when Potts was an active binder, two distinctive sets of tools appeared on multiple copies of Franklin imprints. No one binder of four possible candidates, Potts, Davies, Schuppius or Harrison, could be linked to either set of tools. My only clue was an entry referring to the 1731 edition of Arscot's *Considerations on the Christian Religion*, Part I, which includes a note which says "see Stephen accts." This might be Potts, but I had no record of the binding. The Arscot in which I was interested was the reprint of Part I and II a year later, in 1732, which I had found in multiple copies tooled with the same decorative roll. Of course it was possible that "Stephen" i.e., Potts, could have bound both editions. Against this assumption I had to place the lack of any other appearance of this decorative roll until twenty years later, when it was used on the Franklin imprint of the *Votes and Proceedings of the House of Representatives*, volumes 2 and 3, in 1753/54. The Arscot was an octavo, the *Votes and Proceedings* a folio; while the roll was the same, the general style of the binding was very different - and there was that twenty year gap between its appearances. Potts had been an active binder during this period. Therefore, it seemed quite likely that the *Votes and Proceedings* might be the work of another binder, using the first man's tools.

From time to time, I puzzled over this gap, and tried to close it up in various ways, without success. Then one day I spotted the decorative roll again, this time on a non-American imprint of which I had only happened to make a rubbing. The book was a copy of Bayle's *Historical and Critical Dictionary* ordered by the Library Company in its first purchase in 1730. The minutes of the Library Company for 1743 record payment to S. Potts for binding two volumes of the set in full leather, 13 shillings each. The date, 1743, comes right in the middle of the twenty year gap. What is more, Potts used three decorative rolls on his binding of the *Dictionary* volumes, and these rolls also appear on the 1732 Arscot and another, the 1734 *Constitution of the Masons*, both Franklin imprints; and both in multiple copies on James Franklin's printing of Barclay's *Apology*, Newport 1729, fifty copies of which were imported in sheets by his brother Benjamin; as well as on a number of European imprints in the Library Company's early collection.

When Stephen Potts died in 1758, an inventory was made of his estate. The binding equipment was listed in some detail. It included ten decorative rolls valued at one pound, ten shillings. When I tallied all the rolls used on all the Potts bindings I had identified, I could distinguish nine different rolls plus a fragment known to me only from the board edge of two bindings. My original identification was made in 1964; four years later, I was able to find the

complete design of this last roll on the side of a Library Company book which contains the inscription "Joseph Breintall's May 1730 who had it bound by Stephen Potts Phila."

From what I have said so far, it seems that I have relied almost entirely on decorative rolls for my identification of individual binders. This was true at the beginning of my research, for the simple reason that rolls were the most common form of tooling used on the great majority of American eighteenth century bindings. Handstamps do appear, of course, but not with the same frequency as rolls. As my research progressed, I came to see that decorative

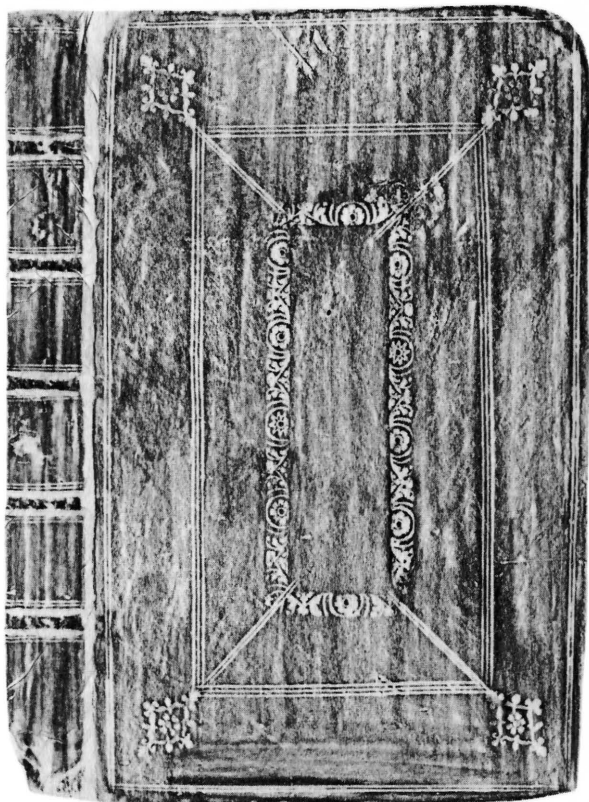

Bound by Nathaniel Holland
Sophia Hume. *An Exhortation to Inhabitants of the
Province of South Carolina*. Philadelphia: printed by
William Bradford (1748).

rolls, like every aspect of life, have their fashions. Rolls that I had thought unique in design began to have copies, sometimes very close copies, and often right in the same city. This is hardly surprising: the handsome scallop roll of one binder is going to be copied by another, in order to please the customer who wants the latest thing.

As my rubbing collection grew, I could see duplicated rolls in many designs, "scallop," "scallop and flower," "grosgrain ribbon and flower," "dotted fillet," and so on. It became essential to devise a way to distinguish between two rolls of the same design. The solution depended on the fact that these rolls were

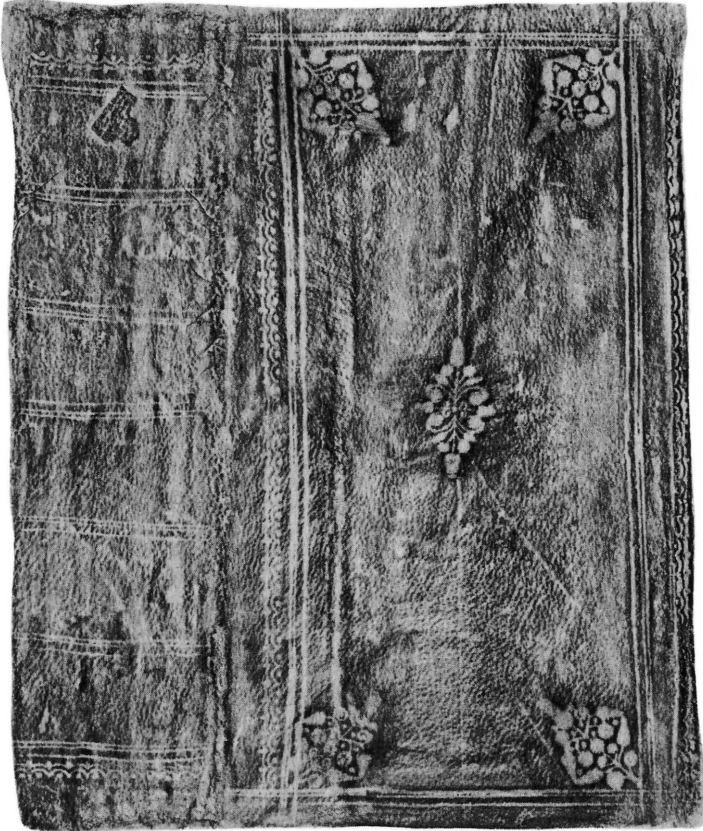

"Bound in Phila^d cost -/2/-/!"
General Magazine and Historical Chronicle. Philadelphia:
1741. Collection American Philosophical Society.

engraved by hand, and so could not be exact copies one of the other. The more of a roll displayed on a binding, the more likelihood that I would be able to pick up irregularities, tiny differences in scale, length of unit, or direction. I have adapted to my use a marvelous tool called a "10-point divider" originally designed for the Navy but for what use I cannot say. Given rubbings of two similar rolls, say the scallop roll, I lay the divider on one roll and set the points on the points of the scallops. Without changing the setting, I then lay the divider on the second roll, trying to align the points on the scallop points. If they coincide, the rolls are very likely the same; if they do not, two separate but similar rolls are involved.

American bindings of the eighteenth century were very little different in appearance or construction from the ordinary British trade bindings of the late seventeenth and early eighteenth century. Leather bindings in England, Scotland, and Ireland were usually made of calf or sheep, blind tooled single or double panel design on the sides; the spine was tooled in blind with parallel lines on either sides of the cords. Gold tooling was reserved for board edges and for titles. American bindings were if anything even plainer than their British counterparts.

The customary material for an eighteenth century American binding was sheep, occasionally calf, with the surface often stained, sprinkled, or marbled. Sheep with the rough side outward was used for account books, ledgers, and similar business records. Bindings in colored leather were rare and did not appear in Philadelphia before 1760, to my knowledge; I have seen only one example of a red morocco binding executed in Philadelphia before that date. Evidence to support my statement comes from the inventory of William Muir's estate made in 1761. Muir was a successful and skillful binder who would surely have bound in colored leather had it been fashionable at the time. Yet his inventory lists only a single box of red and blue morocco pieces, worth one shilling sixpence, as compared with his supply of sheep and calf skins worth over fifty pounds.

In the eighteenth century in America, the sides or boards of a binding were made of one of three materials: pasteboard, binder's or millboard, or wood. The composition of these boards can provide a clue to the origin of a binding: for example, many early Boston bindings use thin wooden boards with a horizontal grain, while Philadelphia bindings more often use pasteboard or millboard. To this rule of thumb there was one exception - the German binders in Philadelphia used wooden boards for much of their binding, but these boards were thicker than Boston boards, and were always grained in the vertical direction. A further clue to the locality of a binding is provided by the practice of some German binders in bevelling the inside edges of their boards. I have never seen such bevelling on Boston's wooden boards.

The method by which the cords or thongs on which a book is sewed are attached to the boards is another important clue. The customary method with pasteboard or millboard is to perforate the board opposite each cord and lace the cord through the board and out again. The German use of wooden boards, rather more difficult to perforate, perhaps explains their method, in which the cords are frayed out, flattened, and pasted to the inside of the boards. The same use of wooden boards may explain the method occasionally seen on Boston bindings, where the cords or thongs are put down on the outside of the boards.

Any mention of cords brings up the perennial question of "raised cords" versus "flat backs," that is, spines with the cords sunk in grooves sawed across the spine. In my experience I have been unable to establish a pattern for the use of either style that relates it to locality, the nationality of the binder, or the style of the binding. While flat backs allow for more variety in tooling, binding with raised cords was more durable (and hence more expensive). I would agree with the British expert, Bernard Middleton, that sawed-in cords were typical of cheaper and thinner bindings, yet I have seen a number of thick books in substantial bindings that still had sawed-in cords. Some binders seem to have worked with equal ease in either style. Thus, the evidence of raised or sawed-in cords is too unreliable and contradictory to use in the identification of specific binders.

Headbands are a perishable feature of a binding, located as they are at the point of greatest stress on the spine. Their loss is all the more regrettable, because the ones that have survived show considerable variety in shape, material, and manner of working. On most eighteenth century American bindings the headband was comparatively simple, usually worked over a cord or a rolled paper strip after the book was sewed. An exception must be made for the German binders, who often embroidered their headbands on vellum or cloth strips. Sometime in the latter half of the eighteenth century, the use of a fancy cord sewed in place was introduced. In the 1790s another innovation came into use: a piece of marbled paper or gingham cloth was pasted over a cord, and the resulting headband simply applied and glued into place. I have found both Boston and Philadelphia bindings with headbands of marbled paper, a practice which seems to have been unnoticed by other writers on binding, although they do mention the use of gingham cloth.

One final detail of construction deserves to be mentioned, if only because it so often overlooked. This is the stationer binder's waste or paste-down, the outside leaf of a book which is pasted down beneath the end-paper. According to his training, a binder will trim with scissors or tear the waste to reduce its size before pasting. The resulting shape may be narrow or wide, clipped top and bottom, shaped like an envelope flap or crescent - it may even be omitted entirely. In any case, each binder invariably treats his waste in exactly the same manner each time, presumably because it did not show and therefore did

not have to conform to any fashion. As a result it is a remarkably dependable clue to a binder's work, once examples of that work have been isolated by tooling or other more obvious details of construction.

Having had such success with the identification of Philadelphia bookbinders by a combination of rubbings and documents, it is understandable that I continued to make rubbings wherever my profession took me. As a consultant in conservation for the past twenty years, I have been called to many libraries on the East Coast, from Boston to Washington, and I have visited many others on vacations and in my free time. Wherever I have gone, I have carried a supply of rubbing paper and pencils with me; the resulting file of rubbings now numbers at least 10,000, from more than ninety collections. Additional rubbings have been contributed by friends and interested persons, to all of whom I must express my gratitude.

Early on in my travels, I was intrigued by the appearance of familiar tools in unfamiliar or unexpected places, but the explanation was not long in forthcoming. In common with other trades of the eighteenth century, binding required a six or seven year apprenticeship, but unlike printing or bookselling, binding required no great amount of capital, equipment, or stock. A binder's tools might cost only a third to a half of a year's wages, and they were reasonably portable. Therefore, binders enjoyed a mobility not possible to practitioners of some other trades. They moved up and down the Atlantic seaboard, and some are known to have worked in as many as three cities in a ten year period.

There are any number of examples of this mobility known to me. For example, the Reverend Jeremy Belknap sent his son Josie from Dover, New Hampshire, to Philadelphia to learn binding and printing from Mr. Aitken. After a stormy and unfinished apprenticeship - Aitken was demanding, and Josie could not meet his standards - young Belknap completed his training in Newburyport with John Mycall, worked there and in Boston for a time, and died at an early age while "travelling in the south."

Again, a binder named William Rookby Sidall, advertising himself as a "London binder," practiced his trade first in Williamsburg in 1766 and then in Newport in 1772. Thomas Brend worked in Annapolis in 1764, in Williamsburg in the early 1770s, and in Richmond, Virginia, after January 1781, where he continued to bind until his death in 1799. In the early eighteenth century, Archibald Simpson travelled about the county seats of Virginia and Maryland, binding courthouse records. There are travelling binders today who continue to do this type of work. When Simpson died in Dorchester County on Maryland's Eastern Shore in 1739, his equipment could be summarized in the phrase, "A parcel of binding tools." Philip Brooke's passage to America was paid by Robert Aitken in 1771, when he was bound

over as a servant to be taught the binding business in three years. By 1775, Brooke had purchased tools from his master and departed for New York, whence he worked his way along the Connecticut coast, being last known in Norwich in 1778. Finally, there is William Aikman, the binder who came from Scotland to Annapolis in 1773 and thence went to Jamaica.

I do not mean to imply that all binders were wanderers, only that their mobility helps to account for the appearance of specific tools in different locations at different times. There is another factor to take into account: the mobility of the tools themselves. Tools could be shared, sold, given away, or bequeathed. I know of one roll used in Philadelphia about 1720 that probably passed through four pairs of hands in its history. Two examples will suffice. Princeton owns the Hannah Boudinot copy of the *Psalms of David* printed in Edinburgh in 1781, and bound by James Leishman using various rolls of which at least one was used in the Aitken shop during Leishman's time there. Apparently the roll came into Leishman's hands when he left Aitken to set up for himself across the Delaware in New Jersey. Thomas Brend, who worked in Annapolis, Williamsburg, and Richmond, did some binding for Jefferson; in rebinding a copy of the *Laws of Virginia*, he used tools that had belonged to William Parks, his predecessor in both Annapolis and Williamsburg.

Looking back over twenty years of research, I am grateful for two things: one, that I began my work in Philadelphia, with its wealth of books and documents; and two, that I did not confine my efforts to Philadelphia. My criteria for making rubbings were not very exclusive; any eighteenth century, leather-bound, American imprint would do - or any other imprint with a binding that to me looked American. As a result of this ambitious beginning, I can now locate samples of binding done in almost all the centers of eighteenth century American life. Philadelphia imprints account for perhaps one-third of the collection. Boston represents more than a third, and New York, Williamsburg, and Newport the balance.

I have been most fortunate in having the cooperation and assistance of my wife and of dozens of friends and colleagues, who send me rubbings, answer questions, and share the joys of this work with me. My wife and I proved with our study of Robert Aitken, published in 1963, that a binder's tools and work could be identified beyond doubt. We repeated it with Francis Skinner of Newport, in a paper published in 1965. In 1974 I compiled an appendix of tools used on Franklin imprints for C. W. Miller's *Bibliography of Benjamin Franklin Philadelphia Printing*, the first bibliography ever attempted in such a catalogue.

In as yet unpublished notes, I have the means of identifying many more of America's eighteenth century binders. I have been told that my enthusiasm for the history of American bookbinding is infectious, and I hope this is true. There is still a great deal of work to be done.

A VISIT TO PHILADELPHIA / Janet Saint Germain

On September 23, 1978, Guild members and friends converged on Philadelphia in order to see the celebrated exhibit "Hand bookbinding today" in the Paley Library of Temple University.

Guild members who were present and who had bindings in the exhibition were Fritz Eberhardt and Alice Press. Other Guild members represented in the show were Don Etherington, Deborah Evetts, Gary Frost, Gale Herrick, Julie A. H. Beinecke Stackpole, and Leah Wollenberg. In all, eighty-two binders were represented in the exhibition.

Mr. Thomas Whitehead and his staff offered us the warmest hospitality with the rare book room open for our perusal and well-stocked with nutritious offerings of coffee, tea, or champagne to keep up our strength. Mementos were offered in the form of handmade paper samples with fine printing commemorating the Guild's visit. We felt most welcome.

The exhibition was truly international and a pleasure to behold. Congratulations to the Hand Bookbinders of California for getting this exhibition together. It opened in San Francisco at the San Francisco Museum of Modern Art, then moved on to the William Rockhill Nelson Gallery, and Atkins Museum of Art in Kansas City, Missouri.

After an informal lunch break, we regrouped to enjoy the fine hospitality of Mr. Willman Spawn and the American Philosophical Society. Just to visit the splendid Federal-style building which is the home of the APS is treat enough; we had the further good fortune of sharing in Mr. Spawn's great expertise and enthusiasm relating to the identification of eighteenth century Philadelphia binders. Mr. Spawn's most interesting and entertaining lecture on this subject led us along the trail on which he has been sleuthing for many years. There were 150 binders in Philadelphia. Some ninety of these have been identified. Incidentally, twenty-two of these ninety binders were Scottish immigrants. Mr. Spawn has made in excess of 9,000 rubbings in order to find a relationship between tools. Mr. Spawn believes there is as much to be seen from the cover of a book as there is from the typography.

We enjoyed a reception with delicious and generous refreshments, surrounded by the many treasures of the APS: portraits, sculptures, and scientific experimental equipment. Cream on the cake was added by the Von Steuben Day parade passing by just outside the window - Hessian troops with fife and drum corps.

A VISIT TO NEW YORK CENTRAL SUPPLY COMPANY / Janet Saint Germain

On November 29, 1979, some seventeen GBW members braved a cold, windy night to gather at the New York Central Supply Company at Third Avenue and 11th Street. Certainly not just a fine-art supply store, New York Central is known as a treasure-trove of fine papers. Our host, Steve Steinberg, and his helpers were most generous in sharing their knowledge and their collection with us. I shall simply say that we saw an enormous variety of fine, handmade papers from all over the world in a profusion of colors, textures, shapes, and prices. Special papers can also be commissioned to order, marbling supplies are stocked, and individual attention is given to unusual problems of printers, binders, and artists.

Refreshments were served and not a few of those present succumbed to the temptation to take home a little "inventory."

BEHIND THE SCENES AT SWANN GALLERIES / Maggy Magerstadt Rosner

"A behind-the-scenes view of how a book auction works . . ." was what our Program Chairperson promised Guild members on February 6, 1979. We were invited to the Swann Galleries in New York City to hear Mr. George Lowry's animated, knowledgeable, and entirely engaging talk about the workings of this distinctive book auction gallery.

Swann is the largest *exclusively* book auction gallery in the United States where books are regularly offered at Public Sale to the highest bidder and Mr. Lowry is the head of the firm. He brings broad experience in the field and a high seriousness to the job and a lively wit to his audience. He began his talk to us by emphasizing the necessity of good, reliable catalog descriptions of books offered at a professional trade auction. Dealers, serious collectors, and librarians are the clientele and it is important that the book be "as described."

The reason for selling books in the open market is the same as it is for other objects auctioned: it establishes competition and perhaps the value of the book. The sale can establish the "fair, objective evaluation" needed in disposing of estate property; it helps circulate and establish current values of historical materials. Mr. Lowry entertained us with descriptions of the "Dutch Auction" and "Candle Auctions." Book auctions originated in Holland as early

as the eighteenth century. For those wondering how the auction gallery makes its money, the answer is that it collects a commission from the seller only. The next question might be where do the books come from that are to be auctioned at Swann Galleries? There are diverse sources - sometimes an individual with a precious volume, but more usually collectors with large numbers of books or libraries with duplicates and inappropriate titles, or institutions re-aligning their collections, perhaps people moving to another area, or people inheriting unwanted books. Times and requirements of book ownership change.

Later Mr. Lowry pointed out that certain books are better not sold at auction. Books in a single subject collection, a small number of items whose price is known, or an owner in a hurry are cases in which it would be better to sell through a dealer. It could take a year before certain books are suitable for a catalog subject listing and auction.

Since many in the audience were engaged in book repair and restoration, in helping *cherish* books, Mr. Lowry did give us the "Big Picture" of the sheer volume of items dealt with at Swann's and the ordinary deterioration problems. Unlike gem or coin auctioneers, some attention will be given to a valuable item that is in desperate condition before presenting it at auction. Otherwise the condition of an item is honestly described in the catalog and then it is up to the new owner to cherish it.

As for members of the staff of the auction house permitting themselves "the pleasure of ownership," Mr. Lowry's assistant, Ms. Gillian Kyles, said, "Auctioneers must sell. They are the intermediaries." The job of the auction house is to place the proper evaluation on the item (a set of books can be an item, too) and then bring it to the attention of the appropriate potential buyer. The catalog must get into the right hands. Catalog production is costly, requiring research, proof-reading, printing, and mailing. Swann has been in business for forty years and its catalogs are distributed throughout the world. Mailing lists must be good.

How does Swann Galleries know how much a book should fetch at auction? Although Mr. Lowry said "estimates don't really create price" and "specialist dealers and collectors know the value better than we do," the Swann staff of experienced assistants, using all sorts of old catalogs, as well as current American book price lists, and their own long memories, can be very accurate. After research is completed, the staff member writes the accurate auction catalog description with the evaluation. In response to a question regarding a non-rare, non-valuable item, a book whose value might be under \$50.00, Mr. Lowry answered that it does not pay to sell it at auction, better to do it through

Maggy Magerstadt Rosner is a bookbinder and long-time member of the Guild of Book Workers.

a dealer. He also explained about the meaning of the term "Negotiated Reserve," which is the bottom price agreed upon between the seller and the auctioneer. If no bid is higher than the agreed minimum, the item is withdrawn from sale. This is appropriate for a valuable or an obscure or an important item. The *fairness* of an auction - every single book will be competed for - appeals to lawyers and to buyers. Collectors enjoy matching wits with professional evaluations and the market price. It is presumed at Swann that the bidders are informed about the market for what they want, and have examined the books previous to the auction and that they won't "get carried away."

As our group was invited to move about into the work area, "behind the scenes," we learned more about the orchestrating of the weekly sale. There may be many consignors for the 350-450 books being sold on a Thursday. These books have come in at various times, been studied, described, evaluated, and wait to be joined with others of their subject. Each sale will have a balance of categories. Some could be "Nineteenth Century First Editions," "Judaica," "Art Nouveau," or "Irish Authors," books in large enough number to interest buyers in that category.

We also saw the "working shelves" for books that had arrived, been unpacked, and were waiting to be cataloged. There are of course books that arrive in a shipment that Swann may regard as not of auction quality. These are dealt with by inviting a dealer to make a "bulk bid." The packing and shipping area looked spacious and efficient, important to a firm that may do as much as eighty percent of its sales by mail.

Most members of the Guild who attended felt it was one of the most interesting views of another aspect of "book working" that we had been privileged to see. It certainly did help give perspective on the sheer number of books there are in the world for those of us who may work for hours or weeks on just one book.

A VISIT TO THE BINDERY

OF FRITZ AND TRUDI EBERHARDT / Janet Saint Germain

On May 12, 1979, about a dozen and a half Guild members and friends met for a delightful and inspiring visit at Fritz and Trudi Eberhardt's bindery in Harleysville, Pennsylvania.

Mr. Eberhardt showed us around the studio and shared many aspects and examples of his craft. Then he offered us some thoughts on "the training of a hand binder." The Eberhardts are deeply concerned that, at present, there is no

protection for the master-binder/teacher from the claims of the dilettante or unskilled binder. He argued cogently and passionately for standards. Everyone agreed to the need for standards. The thorny question of how one might effect this was not solved in the one afternoon.

We proceeded to enjoy the Eberhardt's warm and generous hospitality. Mrs. Eberhardt had prepared delicious baked specialites. A "Mai bowl" was glorious: white wine flavored with woodruff grown in the Eberhardt's wonderful garden. The good company, the beautiful spring countryside, and all within the home and bindery combined to produce euphoria.

I am happy to note that there was a geographical balance reflected in the attendance. About one half of those present were from the New York area and half from New Jersey, Pennsylvania, and Maryland.

*PRESIDENT'S ANNUAL REPORT TO THE MEMBERS, 1978-1979 /
Mary C. Schlosser*

Welcome to the seventy-third annual meeting of the Guild of Book Workers. Tonight we meet for our last official function at the AIGA. After much searching and researching, our Committee for Goals and Future Planning has recommended and arrangements have been made for us to have a mailing address and telephone referral service at 663 Fifth Avenue. Within the limits of our budget it was impossible to obtain our own office with meeting space. However, Guild business has always been conducted from the homes of individual Executive Committee members so we feel confident that no unanticipated problems should arise in our new situation, while continuity and public access to the Guild are provided for. We are very much indebted to Co-Chairmen Sylvia Anderle and Judith Reed and to their Committee for their efforts in what has been a thankless task.

During the year, it seemed necessary to take the unusual step of polling members by mail for a change of Bylaws without waiting for the Annual Meeting. When events moved very quickly last spring, resulting in a decision for dis-affiliation from the AIGA, we found ourselves operating completely outside the Bylaws. Your understanding cooperation, as well as suggestions for the few amendments to be voted on today, was greatly appreciated. I think we can now proceed on firm ground.

Before calling for the reports of the various committee chairmen, I would like to say a few words about our retiring Secretary-Treasurer, Grady Jensen —so redoubtable an officer and so steadfast his services that we have felt it necessary to split his duties between a Secretary and a Treasurer under our

new Bylaws. Grady leaves us to assume his many obligations as the new Mayor of Scarsdale, New York, his "home town." Grady joined the Guild's Executive Committee in Spring 1964 when he became Publicity Chairman. (I especially mourn his departure from the Executive Committee as it leaves me the only member from that time still serving - a hint, perhaps?)

After ten years as Publicity Chairman, in 1975 Grady agreed to become Secretary-Treasurer and has been a dedicated and invaluable officer in that capacity. As the Guild grew larger, he established necessary new procedures for budgeting our monies and when we began to assume control of our finances as separate from those of the AIGA, he ably set up new bank accounts, kept books, paid bills, and most important was responsible for arranging our incorporation as a not-for-profit New York corporation with subsequent recognition of our tax-exempt status by the IRS.

Besides these activities he found time to make the first index of the Guild's *Journals* from Volume I through Volume VIII. He leaves us on a sound financial footing and we are most grateful for his many years of service to the Guild. Three cheers for the Mayor of Scarsdale!

During the year, perhaps the most complicated aspect of the Guild's return from affiliate to independent organization has been that of taking over our membership records from the AIGA and changing from a staggered dues schedule to once-a-year billing. Vice-president/Membership Chairman Jeanne Lewisohn deserves a medal of commendation for her struggles with this onerous task. Now, at last, due to her valiant efforts, everyone will receive a full year's bill in June and we look forward to having a true account of how many members and how much money we have, and to publishing a new membership list which has been impossible during the past year's confusion. A small net increase to 341 members was achieved in spite of everything.

The reports of our Exhibition Chairman Susanna Borghese, Library Chairman Stanley Cushing, Publications Chairman Jerilyn Davis, Publicity Chairman Caroline Schimmel, and Workshop Chairman Nelly Balloffet are largely self-explanatory and bear witness to a great deal of hard work and fine accomplishment, for which we thank them all.

The issuing of a new Supply List under the direction of Supply Chairman Jane Greenfield is a worthy and suitable finale for her many years of service on the Guild's Executive Committee. She first became actively involved in February of 1964 when the Guild's efforts to form a library of books about bookbinding had resulted in the assembly of about seventy volumes and it seemed necessary to create the position of Guild Librarian. Jane Greenfield was duly appointed. In 1966, the GBW Bylaws were revised to make the Librarian a full Executive Committee member, and by 1967, when space in New York was unavailable, Jane took the Library into her own home near New

Haven where it remained until it was transferred to its present location at the Boston Athenaeum and a new Library Chairman was elected in 1974.

However, the Guild is always reluctant to let a good thing get away, so in 1975, Mrs. Greenfield was persuaded to take on the job of Supply Chairman, producing a major new Supply List in 1976 and now again in 1979. Expanding duties as head of the Conservation Studio at Yale force her to limit her volunteer activities at present but her many years of work for the Guild are greatly appreciated.

A final word of thanks is in order for Polly Lada-Mocarski who attempted, on very short notice last fall, to arrange a reception for a group of French binders traveling in this country. It was a valiant and time-consuming effort which finally came to naught due to circumstances beyond all our control.

Looking to the future, the major emphasis in the next year will be on our 75th anniversary exhibition, and on the work of the Standards Committee. Exhibition Chairman Susanna Borghese and her committee are hard at work planning an exhibition to open at the Grolier Club in New York in June of 1981 and perhaps to travel to Chicago and California.

The Standards Committee's work has been delayed owing to the resignation of Chairman Laura Young in anticipation of eye surgery. Don Etherington has agreed to take on the Chairmanship and a meeting of the Committee is planned for the near future.

Lastly, we welcome our new Committee Chairmen elected tonight: Diane Clare Burke, Secretary; William M. Klein, Treasurer; and Jean Gunner, Supply Chairman, and look forward to working with them during 1979-80.

*MINUTES OF THE ANNUAL MEETING,
MAY 17, 1979 / Grady E. Jensen*

The seventy-third annual meeting of the Guild of Book Workers was convened at 7:30 p.m. on May 17, 1979, at the American Institute of Graphic Arts, 1059 Third Avenue, New York, New York. Members present included: Hedi Kyle, Jerilyn Davis, Janet Saint Germain, Nelly Balloffet, Suzanne Schrag, Judith Reed, Mary Greenfield, Susanna Borghese, Mary Schlosser, Caroline Schimmel, Diane Burke, Mindell Dubansky, Deborah Evetts, Hope G. Weil, John Mead, Cynthia Kaufman, Nancy Russell, Inez Pennybacker, Maggy Magerstadt Rosner, Jeanne Lewisohn, Walter Allweil, Anita Kearns, Frances Manola, Grady E. Jensen.

Mrs. Schlosser called the meeting to order and proceeded to call on the various committee chairmen for their annual reports (which are printed in this issue following the 1979 Bylaws Revision).

There was no report from Vice-president at Large Gale Herrick.

In his absence, Mrs. Schlosser read the written report from Stanley E. Cushing, Library Chairman. The Library List is at the printer and will be fifty pages long. Rules are being set up for the use of the Library.

Mrs. Schlosser also reported on the Standards Committee and Mrs. Young's resignation from the chairmanship in January 1979. Don Etherington of the Library of Congress has agreed to be Chairman.

The Study Opportunities list is a popular but ever-changing service of the Guild. Mrs. Schlosser reported that a chairman needs to be found to keep the list current. The list has been up-dated several times and during 1978-79 there were 83 paid requests for copies of the list for which a nominal fee of one dollar is charged.

Nelly Balloffet, Workshop Chairman, reported on the upcoming marbling workshops by Don Guyot and the November 1979 workshops by Bernard Middleton and Philip Smith. She stated that these workshops are self-sustaining. There was discussion on how workshops could be arranged in other cities, but it was felt that this would not be feasible unless a local member came forward to handle local arrangements.

Mrs. Schlosser then asked the Secretary to report on the balloting for the new slate of officers and for revisions in the Bylaws. Mr. Jensen reported on the counts for these and it was moved, seconded, and unanimously approved that one ballot be cast by the Secretary for each. The following persons were elected for the two-year period 1979-81 to the positions indicated:

Vice-president/Membership Chairman	Jeanne F. Lewisohn
Vice-president at Large	Gale Herrick
Secretary	Diane Clare Burke
Treasurer	William M. Klein
Publications Chairman	Jerilyn G. Davis
Supply Chairman	Jean Gunner

With respect to the May 1980 annual meeting of members, Mrs. Pennybacker offered the use of her home in Redding, Connecticut, which offer was received with thanks.

The meeting was adjourned at 8:45 p.m. for refreshments.

TREASURER'S REPORT / Grady E. Jensen

Operating and Cash Statement for 12-Month Period 7/1/78-6/30/79

Cash Balance Carried Forward From 6/30/78 \$ 8,803.36(A)

Income

Membership Dues (Net)	\$7,600.33	
Journal Sales	389.50	
Study List Sales	65.00	
Refund of Insurance Premium	165.00	
Guyot Workshop Fees	1,170.00	
Savings Account Interest	340.00	
Miscellaneous	18.06	
		9,748.59
		18,551.95

Expenses

General Administration	1,433.47	
Rent & forwarding AIGA	2,102.69	
Secretary	861.32	
Membership Committee	220.62	
Publicity Committee	526.38	
Membership Meetings and Program	336.32	
Journal Production and Mailing	1,574.09	
Library Committee	28.64	
Supply Committee	109.63	
Study Opportunities List	39.15	
Middleton Workshop	39.17	
Guyot Workshop	1,140.13	
Miscellaneous	4.55	
		8,416.17
		\$10,135.78(B)

GUILD CASH POSITION

	6/30/78(A)	6/30/79(B)
Balance with AIGA	\$6,407.54	—
Scarsdale NB Checking Acct.	2,395.82	\$ 695.08
Chemical Bank Checking Acct.	—	100.00
Seamen's Bank Savings Acct.	—	4,340.70
USAVE Savings Cert.	—	5,000.00
	\$8,803.36	\$10,135.78

BYLAWS OF THE GUILD OF BOOKWORKERS / 1979 REVISION

FORMATION OF THE GUILD ON NOVEMBER 14, 1906

Two preliminary meetings of bookbinders were held to discuss the needs and aims of an organization of book workers. Two hundred circulars were sent out by Charles Dexter Allen, Katrine W. Carmalt, Fanny Dudley, Sarah Jane Freeman, Fred W. Goudy, Helen G. Haskell, Emily Preston, Lolita M. Perine, Mrs. F. S. Sellew, Mrs. M. G. Starrett, Henry W. Strikeman, Helen Livingston Warren, and Adeline Gaylord Wykes. As a result, the GUILD OF BOOK WORKERS was formally organized Wednesday, November 14, 1906, at a meeting held in the bindery of Miss Emily Preston, 223 East 17th Street, New York City. Forty-two craftsmen were present, representing the crafts of illuminating, printing and binding, and the designing of type, finishing tools, book covers and book plates.

INCORPORATION AS A NOT-FOR-PROFIT CORPORATION

On May 16, 1978, the Guild of Book Workers was incorporated under Section 402 of the Not-for-Profit Corporation Law of the State of New York. The official corporate name is GUILD OF BOOK WORKERS, INC. The Guild is exempt from Federal income tax under section 501 (c) (3) of the Internal Revenue Code.

BYLAWS

(As amended at the annual Meeting of May 2, 1950, in accordance with the Guild's reorganization plan; at the Annual Meeting of April 24, 1962; at the Annual Meeting of April 26, 1966; at the Annual Meeting of May 20, 1976; by a mail ballot of members conducted in November 1978, and at the Annual Meeting of May 17, 1979).

I. Name

The official corporate name of the organization is GUILD OF BOOK WORKERS, INC.

II. Purpose

The purpose of the Guild is to establish and maintain a feeling of kinship and mutual interest among the workers in the several hand book crafts, by forming a center for the collection and distribution of useful and reliable information, by sponsoring lectures and field trips, and by giving exhibitions of the work of its members in cities where local members request them and will assume the responsibility therefor.

III. *Membership*

Practical workers and persons, both professional and amateur, interested in any of the several hand book crafts, are eligible for membership. Membership may be by invitation from the Executive Committee or application may be made to the Membership Chairman.

IV. *Government*

The Guild shall be governed by an Executive Committee composed of the officers and the chairmen of the Standing Committees, all of whom must be members of the Guild in good standing. The Executive Committee shall be empowered to fill vacancies in its membership, but its activities shall be controlled by a majority vote of members of the Guild. The absence of an Executive Committee member from three consecutive committee meetings shall be considered equivalent to resignation from the Committee, unless such excuse as is satisfactory to the Committee be made. The President shall, upon receiving a written request signed by fifteen (15) members, call a meeting of the Guild, which may reconsider any action taken by the Executive Committee.

V. *Officers*

The officers of the Guild shall be a President, Vice-president, Vice-president at Large, Secretary, and Treasurer. The terms of office shall be two years. The President shall be elected in even years; the Vice-president, Vice-president at Large, Secretary, and Treasurer in odd years. Their duties shall be:

President — The President shall preside at the annual business meeting, and shall serve as Chairman of the Executive Committee. The President shall have the power to call special meetings of the Executive Committee at his or her discretion, and shall appoint special committees when deemed necessary. The President shall have authority, along with the Treasurer, to approve bills for payment. The President shall issue at the close of each fiscal year a report to the members, reviewing the activities of the year just ended and outlining the plans for the ensuing year.

Vice-president — The Vice-president shall assume the duties of the President in cases of absence or incapacity. The Vice-president shall also serve as Chairman of the Membership Committee.

Vice-president at Large — The Vice-president at Large shall serve as representative for Guild members out of the New York area. The Vice-president at Large shall carry on correspondence with out-of-New-York members, report to them on the activities of their group and keep the other members of the Executive Committee informed as to their special interests. At the discretion of the Executive Committee, regional representatives may be appointed for geographic areas where sufficient numbers of members warrant.

Secretary — The Secretary shall record the minutes of the annual business meeting and the Executive Committee meetings. The Secretary shall send out notices of the annual business meeting (including ballots), of the Executive Committee meetings, and other general notices not covered by the work of the several Standing Committees. The Secretary shall be responsible for maintaining subscription records for the Guild's *Journal*.

Treasurer — The Treasurer shall keep a record of the Guild's finances, and shall have

authority, along with the President, to approve bills for payment. The Treasurer shall maintain the checking and savings accounts of the Guild and, with the President, have signing authority thereon. The Treasurer shall prepare a budget at the beginning of each fiscal year, periodic financial statements during the course of the year, and a year-end report on the financial condition of the Guild.

VI. *Standing Committees*

There shall be eight Standing Committees - Exhibition, Library, Membership (whose chairman is also Vice-president), Program, Publications, Publicity, Small Exhibition, and Supply. The chairmen of these committees shall be members of the Executive Committee. If there are co-chairmen of a Standing Committee, both shall be members of the Executive Committee. Their term of office shall be two years. The chairmen of the Exhibition, Library, Program, Publicity, and Small Exhibition committees shall be elected in even years; Membership (also Vice-president), Publications, and Supply in odd years. Each chairman may form his or her own committee from the Guild membership rolls, and may call meetings of his or her committee at his or her discretion. At the close of each fiscal year the chairman of each Standing Committee shall send to the President a report on the activities of his or her committee. The separate duties of these committee chairmen shall be:

Exhibition — The Exhibition Committee shall have entire responsibility for all Guild or Guild-sponsored exhibitions. It shall keep an exhibition scrapbook in which copies of all printed pieces pertaining to exhibitions shall be kept in an orderly manner, and shall maintain records of all items exhibited by the Guild.

Library — The Library Committee shall have responsibility for the Guild's library. It shall have the right of selection in the purchase of new items, when funds are available, and shall issue once a year a list of new acquisitions. It shall also endeavor to keep the membership informed of new publications.

Membership — The Membership Committee shall keep an accurate and up-to-date list of all Guild members. It shall conduct all membership drives, bill members annually for dues, and shall be constantly seeking new members. It shall keep in some accessible and neat form biographical material on all members.

Program — The Program Committee shall have the responsibility of arranging a minimum of two program meetings annually. The chairman of the committee shall preside at these meetings, or arrange for a substitute. A program meeting may be held in conjunction with the annual meeting. The chairman shall be responsible for recording or having recorded accurate accounts of these meetings for distribution to Guild members.

Publications — The Publications Committee shall be responsible for all aspects of publishing the *Guild of Book Workers Journal* other than the preparation of original copy. These responsibilities will include setting schedules and due dates; calling for copy from the various officers and standing committee chairmen; editing copy; working with the compositor and printer; maintaining detailed cost records for each issue; mailing copies of completed *Journals* to the membership; distributing file copies to each standing committee chairman; working with the Secretary in the distribution of *Journals* to subscribing libraries and other subscribing organizations; and ensuring that inventories of back issues are sufficient in number. Responsibility for the content or 'theme' of each issue of the *Journal* will be rotated among the members of the Executive Committee, who will work with the Publications Chairman.

Publicity — The Publicity Committee shall be responsible for sending to the various

news media information concerning Guild exhibitions and their activities of general interest. Any resulting publicity shall be preserved in the Guild files. This committee shall keep the membership informed of exhibitions, lectures and activities of interest that are not sponsored by the Guild. It shall keep a file of all available printed publicity received by Guild members.

Small Exhibition — The Small Exhibition Committee shall be responsible for soliciting and assembling small exhibitions of bindings, calligraphy, decorated papers and related items for showing in various appropriate locations as may be available. The primary purpose of this committee shall be to provide a showcase for the work of individual members.

Supply — The Supply Committee shall issue periodically a list of dependable dealers in supplies which are of interest to members; this may be a new list or in the form of a supplement. It shall advocate the use of quality materials; and shall encourage a scientific or analytical approach to the testing of new materials. It shall be empowered to set up a schedule for cooperative buying within the Guild, when desirable.

Nominating — In January of each year, the President shall appoint a Nominating Committee of three members, one of whom shall be designated as Chairman. The President shall be an ex-officio member of the Nominating Committee. The Nominating Committee is responsible for proposing candidates for the Executive Committee for those positions whose terms will end at the end of the current year. Additional nominees for positions to be filled may be proposed by members at large. Such nominations must be accompanied by (1) a biographical sketch of the nominee, (2) a written statement by the nominee that he or she is willing to serve if elected, and (3) signature endorsements of five (5) members at large supporting the alternative nomination(s).

VII. *Special Committees*

Special committees for particular projects or purposes may be established at any time by the President. During the active lives of such special committees, the chairmen shall act as members of the Executive Committee but will not be entitled to vote as members of the Executive Committee.

VIII. *Dues*

Annual membership dues shall be established by the Executive Committee. Categories of membership shall be:

Resident	Within 50 miles of New York City
Non-Resident	Beyond 50 miles from New York City
Junior	Through 25 years of age

Other categories of membership may be added at the discretion of the Executive Committee.

IX. *Exhibitions*

It shall be the policy of the Guild to hold exhibitions of the work of the members from time to time; and to accept invitations to exhibit when they seem, in the opinion of the Executive Committee, to be in the Guild's interest. All items for exhibition shall conform to the standards and specifications of the Guild; and all Guild exhibitions shall be juried. The jury shall be selected by the Executive Committee.

X. Meetings

The business meeting shall be held annually in the spring, in the City of New York. There shall be at least two other scheduled meetings under the direction of the Program Committee. All scheduled meetings shall be held, when possible, in the evening. The Executive Committee shall hold a minimum of five scheduled meetings annually, the dates and time to be mutually agreed upon at either the meeting immediately preceding or following the annual meeting.

XI. List of Members

A list of all Guild members, their mailing addresses, and their areas of specialty or interest in the hand book crafts shall be published annually.

XII. Voting

All active members in good standing shall be entitled to vote. The annual election of officers, and all matters of Guild policy, shall be voted upon by written ballot. Ballots shall be mailed to all members not less than two weeks before the annual business meeting. For a change in the Bylaws, a two-thirds majority of the votes cast shall be required.

XIII. Fiscal Year

The fiscal year shall run from July 1 to June 30.

XIV. Parliamentary Authority

The rules contained in Robert's Rules of Order (latest edition) shall govern the association in all cases to which they are applicable and in which they are not inconsistent with the Bylaws of this association.

GOALS AND FUTURE PLANNING / Sylvia Anderle and Judith Reed

During the year 1978-79 the Goals and Future Planning Committee investigated several other suggested locations for the Guild headquarters. However, none were able to fulfill our needs. Therefore, the committee was asked to look into mail forwarding and telephone answering services. Upon reporting the results of the committee's findings, the Executive Committee agreed to make arrangements with one of these office service facilities, which will provide the Guild with daily mail forwarding service to the President and telephone referral service to appropriate Executive Committee members. The Guild's name will also be listed in the lobby directory board and eventually in the Manhattan telephone directory.

Our new address will be 663 Fifth Avenue, between 52nd and 53rd Streets, which was chosen because of its competitive rates and well-established operation at a convenient central location.

EXHIBITION / *Susanna Borghese*

The Exhibition Committee is very pleased to announce that a show celebrating the 75th Anniversary of the Guild of Book Workers has been planned for June of 1981 at the Grolier Club in New York City. Part of the exhibition will be a retrospective of major works by important early members of the Guild; the balance of the show will consist of works by present members which have been recently executed and not before shown at a major exhibition. Examples of fine binding, calligraphy, restoration, decorated papers, boxes, or any of the related book arts will be considered by a panel of expert jurors. All members are encouraged to begin work immediately, in preparation for this great event. Further information will follow in future newsletters and mailings.

LIBRARY / *Stanley E. Cushing*

During the year, work continued on getting the completed Library List printed and in the hands of the membership. Proofs have been read and corrected and hopefully the list will be distributed soon.

While only eight members borrowed books since our last report, we expect the new Library List to stimulate our members' interest in the holdings of the Library.

Additions to the Library have been numerous. Princeton University Library donated *Fine Bindings, Gothic to Modern*, a catalog of an exhibition held from April 21 - September 4, 1978, and organized by GBW member Jamie Shalleck. *Decorated Book Papers* by Rosamond B. Loring, Harvard College Library, Cambridge, 1973, was given by GBW member Doris Freitag. A. S. Barnes and Company donated *Private Press Work* by Frank J. Anderson, New York, 1977. Another publisher's gift was *Reader, Lover of Books, Lover of Heaven* compiled by David B. Kotin, North York Public Library, Willowdale, 1978.

GBW Member Emily Ellenport donated a bookbox to protect *Bookbinders and their Craft* by S. T. Prideaux. The American Chemical Society gave the Library *Preservation of Paper and Textiles of Historic and Artistic Value* edited by John C. Williams and published in 1977. The Preservation Office of the Library of Congress donated the W. J. Barrow Research Laboratory's seven volume *Permanence/Durability of the Book. The Lessing J. Rosenwald Collection*, Washington, D.C., 1977, was given by the Library of Congress. GBW member Ellen McCrady donated Volume I, Numbers 5, 9, 10, 11, 13, 15 and Volume 2, Numbers 1, 2, 3, 4, 5, of *The Abbey Newsletter*.

In exchange for the publications of the Guild of Book Workers, the Library will be receiving *The Imprint of the Stanford Libraries Associates* (starting with

Volume IV, Number 1, April, 1978); the *AIC Newsletter* (starting with Volume 4, Number 1, November 1978); *The Paper Conservator* (starting with Vol. 2, 1977); and *Paper Conservation News* (starting with Number 7, June 1978).

MEMBERSHIP / Jeanne Lewisohn

Seventy-three new members have joined the Guild since the last annual meeting. There were fifty-nine resignations, giving a net increase during the 1978-79 year of fourteen. Guild membership now stands at 341 individual members.

Geographic distribution of members includes 80 in the greater New York area, 45 in New York City; 28 in Massachusetts; 25 in California; 24 in the Washington-Maryland-Virginia area; 20 in Connecticut; 20 in New Jersey; 18 in Pennsylvania; 16 in Canada; and the balance are scattered. There are only 12 states with no members.

PROGRAM / Janet Saint Germain

We were very fortunate to have a wonderful opening program last September 23, 1978, in Philadelphia. We started out (somewhat less than ten Guild members) at the Samuel Paley Library at Temple University where we toured the exhibition "Hand bookbinding today." Warm hospitality with refreshments were graciously offered by Mr. Tom Whitehead and his library staff.

After a free lunchtime, we met at the American Philosophical Society to hear Mr. Willman Spawn address us on "Identifying Eighteenth Century Philadelphia Binders." Mr. Spawn's great expertise and enthusiasm alone would have rendered us content. However, the Spawns went on to offer us splendid food and drink in the wonderful surroundings of the Philosophical Society's exhibit hall. Historical portraits and scientific devices all attested to the Society's greatness. It was a privilege to visit therein!

On November 29, 1978, Guild members visited the New York Central Supply Company at Third Avenue and 11th Street. President Steve Steinberg was a marvelous host and shared his time and his very special collection of handmade papers with us. Papers of all kinds and from all over the world were made available for inspection and the subject of questions. Refreshments were served.

On February 6, 1979, the Guild was invited behind the auction scene at the Swann Galleries at 104 East 25th Street. Mr. George Lowry, President of the Galleries and Guild member kindly welcomed us and explained all the intricacies of a book auction. Swann is the largest book auction house in the world and even our tour of the premises could not dispel the mystery of such a fascinating world. More refreshments!

May 12, 1979, was a red letter day: our visit to Trudi and Fritz Eberhardt's home and bindery in Harleysville, Pennsylvania. After a tour of the bindery, a discussion of "Training a Bookbinder" and of applying standards to the work of practicing binders, we enjoyed delicious refreshment and delightful company.

On June 14th we finished our season's programs with a lecture by Don Guyot on "Ebru: the Turkish Art of Marbling."

PUBLICATIONS / Jerilyn G. Davis

As decided at the Executive Committee meeting on November 16, 1978, a special Journal Committee met at Sylvia Anderle's house on December 2, 1978. In attendance were Mary Schlosser, Judy Reed, Sylvia Anderle, and Jeri Davis. The meeting lasted the entire day, but we feel that much was accomplished and that it was a day well-spent. Decisions were:

The Library List will be published as a separate gray list as it has been in the past.

Vol. 14, No. 3, Spring 1976 will be printed as a regular *Journal*.

Vol. 15, Nos. 1, 2, 3, 1976-77 will be one issue.

Vol. 16, Nos. 1, 2, 3, 1977-78 will be one issue.

Vol. 17, Nos. 1, 2, 3, 1978-79 will be one issue.

Thereafter two numbers of each volume will be issued.

All of these *Journals* will consist of approximately sixty pages, that being the maximum number that can be neatly folded and stitched.

The Publications Committee for next year will be composed of Anne Gordon, Joan Diamant, and Bob Shepherd. Three Executive Committee members will work with the Publications Committee for the publication of each *Journal*.

The Newsletter alerts members to *Journal* themes; I urge all of you to submit material.

My thanks go to Judy Reed, Sylvia Anderle, members of the Executive Committee, Maggy Rosner, Diane Burke, and especially to our president, Mary Schlosser, for the help needed to get the *Journal* ball rolling again.

PUBLICITY / Caroline Schimmel

It was with some trepidation, justified I now discover, that I agreed to take over from Lansing Moran the position of Publicity Chairman and Newsletter editor. Fortunately, her files and her advice were excellent, and you should all have received the four quarterly, if irregular, issues for the past year. The aim of the Newsletter, as envisioned by the GBW Executive Committee, has been to offer a more timely but ephemeral publication than the Journal. To emphasize its transitory nature, your editor has craftily included a scattering of typos in each issue.

News of forthcoming Guild events is included, and, where possible, coverage of past ones. An important aspect should be news from individual Guild members, whether of participation in exhibitions, lectures or courses offered, books published, or even births. But that aspect depends almost entirely on news supplied by the membership, and we would most certainly wish to encourage the membership to be less reticent.

Information and newsletters are exchanged with twelve other organizations, and we have been pleased to note mention of Guild activities in the Abbey Newsletter, AB Bookman's Weekly, the AIC Newsletter, and the American Printing History Association Letter.

SUPPLY / Mary E. Greenfield

It has been a pleasure to serve on the Executive Committee. However, I am glad that my work on the 1979 Supply List is finished. A number of old suppliers were dropped and an equal number of new ones added, so the list has not changed in size.

WORKSHOPS / Nelly Balloffet

This spring (1979) the Guild sponsored two Marbling Workshops, given by Donald A. Guyot of the Colophon Bindery in Seattle. Twenty-four people participated in this excellent presentation of the history and technique of Turkish water marbling (Ebru). We were fortunate to have the bindery of the New York Botanical Garden for the workshop and were given the greatest cooperation by everyone in the library.

In early November we will again be sponsoring a Bernard Middleton workshop in leather restoration and later in the month Philip Smith will be having a demonstration of his unique methods. These will also be held at the New York Botanical Garden.

Members who have suggestions for possible future workshops should contact the Workshop Chairman, Nelly Balloffet at 259 Illington Road, Ossining, N. Y. 10562.

*REPORT OF VISIT OF CHAMBRE SYNDICALE NATIONALE
de la RELIURE-BROCHURE-DORURE (PARIS)
TO GUILD OF BOOK WORKERS (NEW YORK CITY) / Polly
Lada-Mocarski*

The Guild of Book Workers was asked by the *Chambre Syndicale Nationale de la Reliure-Brochure-Dorure* in Paris if they would be able to receive the twenty or so hand bookbinders coming to New York briefly on their way to the *Hand bookbinding today, an International Art* exhibition in Philadelphia. In fact, they had open only two hours on Monday afternoon, September 18th, from 5:00 to 7:00 p.m., as they were leaving the next morning for Philadelphia.

Through the courtesy of the Grolier Club in New York City, a small reception was arranged. About forty or fifty GBW members, all living either in New York City or nearby, were invited. Alas, no time for a general mailing to all members was possible. Tea, sweets, and chilled white California wine were to be served in the large exhibition room. A tour of the Library and small exhibition room was also arranged.

Four days before the day of the reception, a telegram from Paris arrived, saying that the group would arrive too late for the reception but could they come the next day for a short visit. Every effort was made to change the date, but three possible places, as well as the Grolier Club, were not available. The reception had to be cancelled much to our sorrow. All GBW members had to be reached and told not to come!

However, on Tuesday, the 19th (the next day), at 5:15 p.m., the whole French group came to the Grolier Club, unannounced, asking to see the Club in ten minutes. The Librarian's assistant, Mrs. Goetz, who speaks French, very kindly let them in and rushed them through the Club in the required ten minutes. Needless to say, they were delighted and grateful.

We who missed their visit were sorry not to have met our Paris colleagues and have a chance to talk with them and exchange bookbinding news and thoughts. We hope they will come again and stay longer.

Guild of Book Workers Journal

In an effort to put the *Journal* on a current basis, the Executive Committee has decided to publish Volume XV (1976-77), Volume XVI (1977-78), and Volume XVII (1978-79) as individual issues combining the three numbers for each volume. Institutional subscribers will receive these three combined issues at the rate regularly charged for the three issues of one annual volume.

Beginning with Volume XVIII (1979-80) the *Journal* will appear biannually.

The *Journal* is edited voluntarily by members of the Executive Committee in rotation. The editors of each issue appear on the Table of Contents page. Please send reports and articles for consideration to the Publications Chairman.

Back issues of the *Journal* can be purchased through the Secretary.

Executive Committee 1978-1979

President: Mary C. Schlosser

Vice-president: Jeanne Lewisohn

Secretary-Treasurer: Grady E. Jensen

Vice-president at Large: Gale Herrick

Committees:

Exhibition: Susanna Boghese, *Chairman*

Library: Stanley E. Cushing, *Chairman*

Sara Haines

Membership: Jeanne Lewisohn, *Chairman*

Program: Janet Saint Germain, *Chairman*

Publications: Jerilyn G. Davis, *Chairman*

Sylvia Anderle, Anne Gordon,

Judith Reed, Mary Schlosser

Publicity: Caroline F. Schimmel, *Chairman*

Small Exhibitions: Hedi Kyle, *Chairman*

Supply: Mary E. Greenfield, *Chairman*

Workshops: Nelly Balloffet, *Chairman*